

ROI/NI_{v1}



TRACEY
CONCRETE

Drainage Brochure

DESIGNING | MANUFACTURING | DELIVERING

waterlight 



traceyconcrete.com



Tracey Concrete is one of the largest precast concrete manufacturers in the UK and Ireland.

Tracey Concrete's success has been built on the consistent quality of our products, efficient delivery and outstanding customer service. With our vast experience and expertise in the construction industry, we have been able to design and supply precast concrete products for some of the biggest projects in the UK and Ireland.

Our products comply with all necessary certifications and are accredited with the most up to date Irish, UK and European standards, with the relevant products being BSI kitemarked and CE marked.

WE SPECIALISE IN

- Precast Concrete Drainage Systems
- Precast Tunnelling Systems
- Agricultural Precast
- Cable Trough Systems
- Ready-mix and Liquid Screed Concrete
- Bespoke Precast Concrete Systems
- Bio Klenze™ Sewage Treatment Systems
- Quarry Products



Tracey Concrete's Precast Drainage Factory - Enniskillen

Our Story

Tracey's began as a family-run contracting business in the early 1960's installing watermains throughout Northern Ireland. In the 1970's, Tracey Concrete Ltd was formed as a readymix concrete supplier to the public.

Over the years, the company expanded into new product ranges manufacturing precast concrete cills & lintels and agricultural cattle slats. In the 1990's, the business expanded into precast drainage products manufacturing concrete pipes and manhole rings becoming a leading precast drainage supplier in Ireland.

In 2003, Tracey Concrete entered the UK market supplying projects in England, Scotland and Wales. Tracey Concrete are now a leading supplier of Precast Drainage and Tunnelling throughout the UK and Ireland.



Tracey Readymix Lorry 1970's



Tracey Concrete's Belcoo Quarry



Contents

Spigot & Socket Pipes	6 - 11
Dry Weather Flow Pipes	12
Lifting & Handling	13
Perfect Base™ Intro	14 - 15
DN 1200 Perfect Base™, WT Manhole Rings & Cover Slabs	16 - 17
DN 1500 Perfect Base™, WT Manhole Rings & Cover Slabs	18 - 19
DN 1800 Perfect Base™ Manhole Rings & Cover Slabs	20 - 21
DN 2100 Perfect Base™ Manhole Rings & Cover Slabs	22 - 23
Standard Manhole Rings & Cover Slabs	24 - 25
All Pipe Types & Adjustable Core Heights	26 - 27
Perfect Base™ - How It Works	28 - 29
The Seal, Quality and Testing	30 - 31
The Perfect Installation Guide	32 - 35
The Perfect Sticker & Pan Tilt	36 - 37
Concrete Pipe Connections & Complete WT Chamber	38 - 39
Flow Control Chambers & Pump Chambers	40 - 41
Manhole Ring Accessories & Soakaways	42 - 43
Precast Inspection Chambers	44 - 45
Junction Boxes & Attenuation Systems	46 - 47
Seating Slabs & Gullies	48 - 49
Catchpits & WT Catchpits	50 - 51
Headwalls	52 - 55
Product Lifting Equipment	56 - 57
Meet The Team & Corporate & Social Responsibility	58 - 59

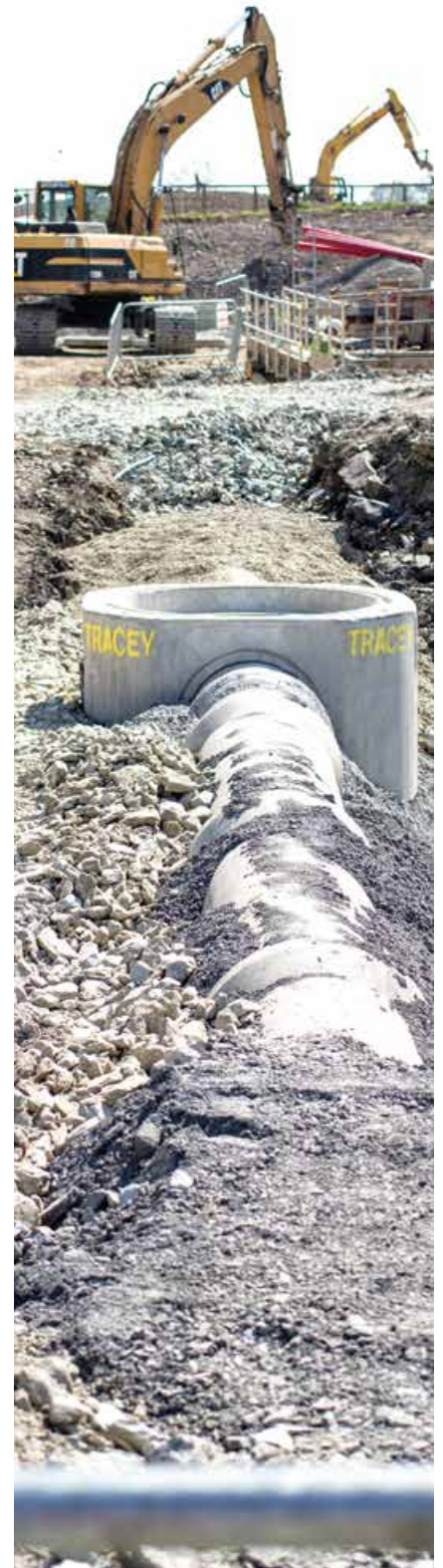

SPIGOT & SOCKET PIPES

DN225 - 2100

Tracey Concrete offers a wide selection of Spigot & Socket Pipes in a range of diameters and lengths to meet any project specifications. Manufactured to British Standard BS EN 1916 & BS 5911-1 and BSI Kitemarked.



SPIGOT & SOCKET PIPES / DN225 - 2100

Size Internal Dia	mm	225	300	375	450	525	600	675	750	900	1050	1200	1350	1500	1800	2100
Barrel Dia	mm	331	405	485	580	675	780	855	940	1100	1280	1470	1650	1830	2180	2480
Socket Dia	mm	445	540	650	730	805	920	1015	1090	1290	1370	1660	1820	2000	2290	2590
Effective Length	mm	2500	2500	2500	2500	2500	2500	2500	2500	2500	2500	2500	2500	2500	2500	2500
Overall Length	mm	2595	2600	2595	2595	2610	2600	2600	2632	2632	2620	2640	2650	2640	2650	2645
Approx Weight	KG	280	430	580	760	930	1230	1370	1745	2190	2730	3980	4745	5755	7600	9210
To suit Manhole	mm	1050	1200	1350	1350	1500	1500	1500	1800	1800	2100	2100	2400	2400	2700	3000
Maximum Deflection	°	2	2	2	2	2	2	2	1	1	1	1	0.5	0.5	0.5	0.5
Reinforced	Y/N	N	N	N	N	N	N	Y	Y	Y	Y	Y	Y	Y	Y	Y
Lifting Anchor	-	-	-	-	-	-	-	-	-	-	-	2x7.5T	2x7.5T	2x10T	2x10T	2x10T
Integrated Joint	Y/N	N	Y	Y	Y	Y	Y	Y	Y	Y	Y	N	N	N	N	N
Lamell Joint	Y/N	Y	Y	Y	Y	Y	Y	Y	Y	Y	Y	Y	Y	Y	Y	Y

Spigot & Socket pipe sizes DN1200 & above are manufactured with 2No lifting anchors for spherical 10T lifting Shackles

ROCKER PIPES DN225 - 2100



ROCKER PIPES / DN225 - 2100

Size Internal Dia	mm	225	300	375	450	525	600	675	750	900	1050	1200	1350	1500	1800	2100
Effective Length	mm	600	600	600	600	600	600	820	1000	1230	1245	1180	1310	1290	1300	1330
Approx Weight	KG	79	120	159	270	332	438	485	913	1133	1421	2290	2614	3117	4158	5137

SPIGOT BUTT END PIPES DN225 - 2100



SPIGOT BUTT END PIPES / DN225 - 2100

Size Internal Dia	mm	225	300	375	450	525	600	675	750	900	1050	1200	1350	1500	1800	2100
Effective Length	mm	1250	1250	1250	1250	1250	1250	1250	1250	1250	1250	1250	1250	1250	1250	1250
Approx Weight	KG	140	215	290	380	465	615	685	873	1095	1365	1990	2373	2878	3800	4605

Lengths may vary depending on availability

SOCKET BUTT END PIPES DN225 - 2100



SOCKET BUTT END PIPES / DN225 - 2100

Size Internal Dia	mm	225	300	375	450	525	600	675	750	900	1050	1200	1350	1500	1800	2100
Effective Length	mm	1250	1250	1250	1250	1250	1250	1250	1250	1250	1250	1250	1250	1250	1250	1250
Approx Weight	KG	140	215	290	380	465	615	685	873	1095	1365	1990	2373	2878	3800	4605

Lengths may vary depending on availability



DOUBLE SPIGOT PIPE DN225 - 900



DOUBLE SPIGOT PIPE / DN225 - 900

Size Internal Dia	mm	225	300	375	450	525	600	675	750	900	1050	1200	1350	1500	1800	2100
Effective Length	mm	495	570	530	730	820	825	820	1125	1145	-	-	-	-	-	-
Approx Weight	KG	55	80	95	184	283	349	415	757	924	-	-	-	-	-	-

JUNCTIONS* DN225 - 2100

JUNCTIONS / DN225 - 2100

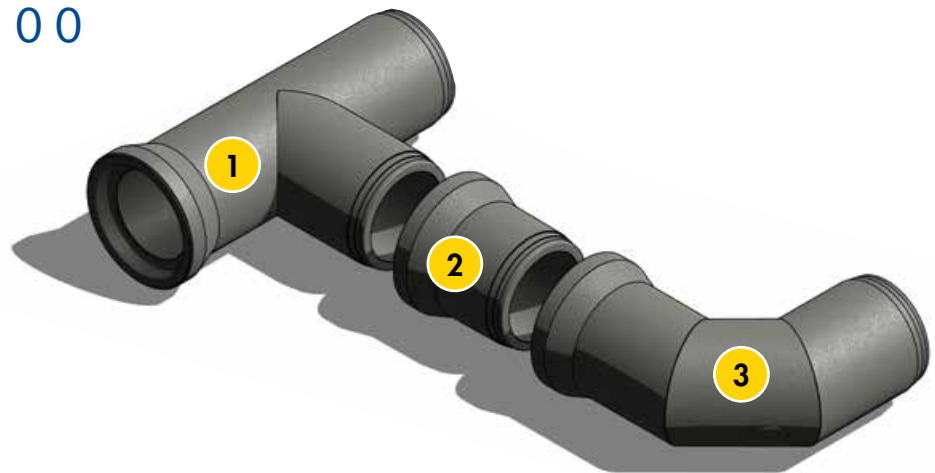

- 1 Tumbling Bay
- 2 Special Length Pipe
- 3 90 Degree Bend

* Note - Only made to order*

BENDS* DN225 - 2100

BENDS / DN225 - 2100

Common Angles
11.25 °
22.5 °
45 °
90 °



* Note - Only made to order*
* Other angles available on request*



JUNCTION SEALS

Junction seals to suit 100mm & 150mm pipe connections can be fitted to all sizes of our concrete pipe.

Seals are supplied to suit branches made from solid wall PVC, rib sewer, twin-wall surface drainage, supersleeve clay & densleeve clay.

Junction Seals can be fitted to a full length pipe or rock-er pipes in positions to suit site requirements.

Junctions to suit other pipe sizes and types are available on request.



150mm Twinwall



Forsheda 910
202 x 16mm

150mm Solid Wall PVC



Forsheda 910
190 x 20mm

150mm Ultra - Rib



Forsheda F-910
202 x 20mm



Branch Adaptor

The **Branch Adaptor** is designed to allow a DN150 (6") plastic to be installed into a new or existing concrete pipe line. The junction can be installed by the pipe producer or on site.

Advantages

- Easy fit to concrete pipes > DN300
- Joining pipe cannot intrude on flow of main pipe-line. A common cause of blockages
- Complies with EN295 air test requirements under deflection and shear loading



LIFTING AND HANDLING



Lubricant



■ Step 1

Before assembly, inspect the pipes and ensure socket and spigot are free from gravel or dirt. Use a damp cloth to wipe the seal clean.



■ Step 2

Using **ONLY TRACEY CONCRETE** supplied lubricant apply it to the spigot end of the pipe. See our website for number of tubs of lubricant required per diameter of pipe. www.traceyconcrete.com/pipes

■ Step 3

Ensure the lubricant is evenly applied all around the spigot end. Lubrication is easier with the pipe suspended off the ground. Dry jointing can lead to damage of the seal and pipe.



■ Step 4

Centre the pipes in position then push the spigot into the socket end. Inspect pipes after installation to ensure assembly is complete. Air tests can then be carried out regularly using inflatable stoppers.



Important Jointing Information

The integral pipe-seal jointing system used in Tracey Concrete's Spigot & Socket Pipes requires the use of an approved proprietary lubricant, which is available for supply with all pipe orders from Tracey Concrete sales team. Failure to use the approved proprietary lubricant in accordance with the instructions provided by the pipe-seal manufacturer and Tracey Concrete may give rise to problems with pipe jointing and seal performance and invalidate any warranty, implied or otherwise. Tracey Concrete accepts no responsibility whatsoever for problems or loss of performance arising from any such failure.

DRY WEATHER FLOW PIPES DN900 - 2100

Dry weather flow channels are cast into the spigot & socket pipe during factory production as an off-site solution. Insufficient flow velocities during dry weather flow can increase retention time in pipes and if channels are not designed correctly can lead to undesirable sedimentation of solid particles.



*Only manufactured to order

CASE STUDIES



Roadbridge - Dublin Airport

In 2020 Tracey Concrete supplied Roadbridge for the new runway at Dublin Airport. Precast concrete pipes, manhole rings & headwalls were all part of the products supplied. The runway is part of the government's € 11.6 billion Project Ireland 2040 plan to modernise infrastructure, remove bottlenecks and enable future growth.



The 3.1-kilometre runway will be located almost 1.7-kilometres north of Dublin Airport's current main runway. Construction is expected to take two years supporting the creation of 31,200 new Irish jobs.



Tracey Concrete Ltd
www.traceyconcrete.com
T HeadOffice: 028 44 324437
E HeadOffice@Traceyconcrete.com



SISK - Centre Parcs

In 2018 Tracey Concrete were selected to design and manufacture bespoke Perfect Bases and a full precast drainage package for the new Centre Parcs project in Longford.



Due to testing ground conditions using the Perfect Base system allowed for faster install of the drainage foul & sewer manholes in turn lead to completing the civils ahead of the already tight timelines.



Tracey Concrete Ltd
www.traceyconcrete.com
T HeadOffice: 028 44 324437
E HeadOffice@Traceyconcrete.com



BAM Wills JV - N5 Castlebar

In 2020 Tracey Concrete supplied €241 million BAM Wills JV contract for N5 Westport to Lough Road. The project involves the construction of 20.3km of dual carriageway from Westport to Lough. Tracey Concrete supplied a full drainage package including headwall, Pipes, Manholes & Gullies.





Tracey Concrete Ltd
www.traceyconcrete.com
T HeadOffice: 028 44 324437
E HeadOffice@Traceyconcrete.com

LIFTING AND HANDLING

Tracey Concrete's pipes from DN1200 and upwards should be handled using our spherical lift anchor system. 10T lifting anchors are cast into the pipe during manufacture to suit a spherical lift shackle that hooks to the anchor to lift the pipe. All lifting equipment is available from Tracey Concrete.

Firstly lift the new pipe into place using equal length chains (A & C) as shown below. Then to join the pipes together fit the longer chain (B) to the pipe already in place, then hook the shorter length chain (A) onto the new pipe in the arrangement shown below. Lift the chains vertically and the new pipe will then joint into the pipe already in place.

THE CHAIN SET

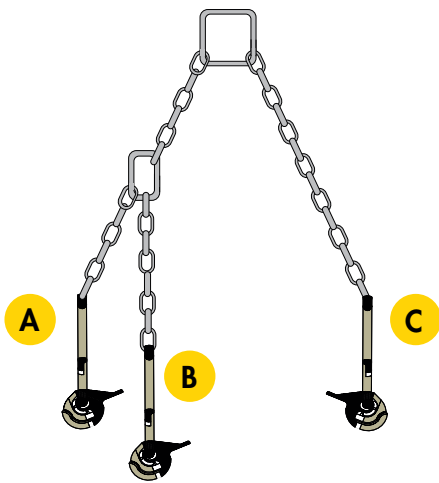

FITTING THE SHACKLE

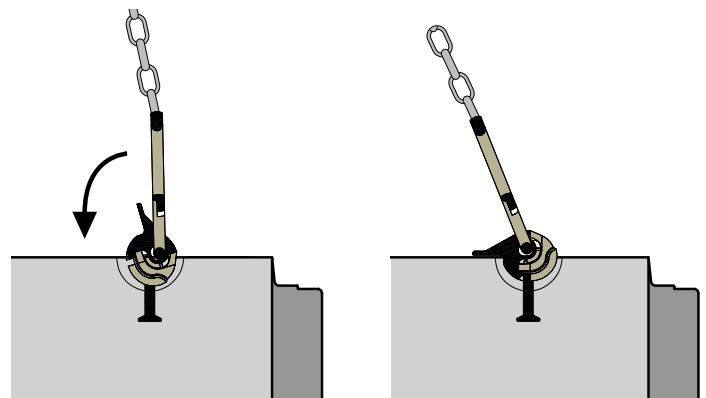

POSITION SHACKLE

THEN ENGAGE

LIFTING & HANDLING

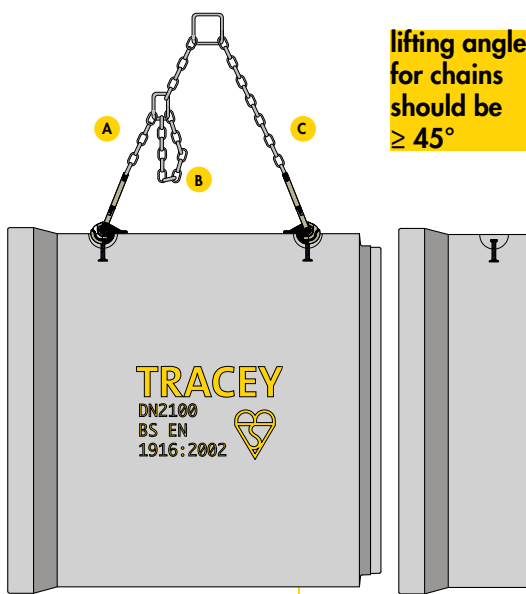

Place new pipe as close as possible to already installed pipe

JOINTING PIPES

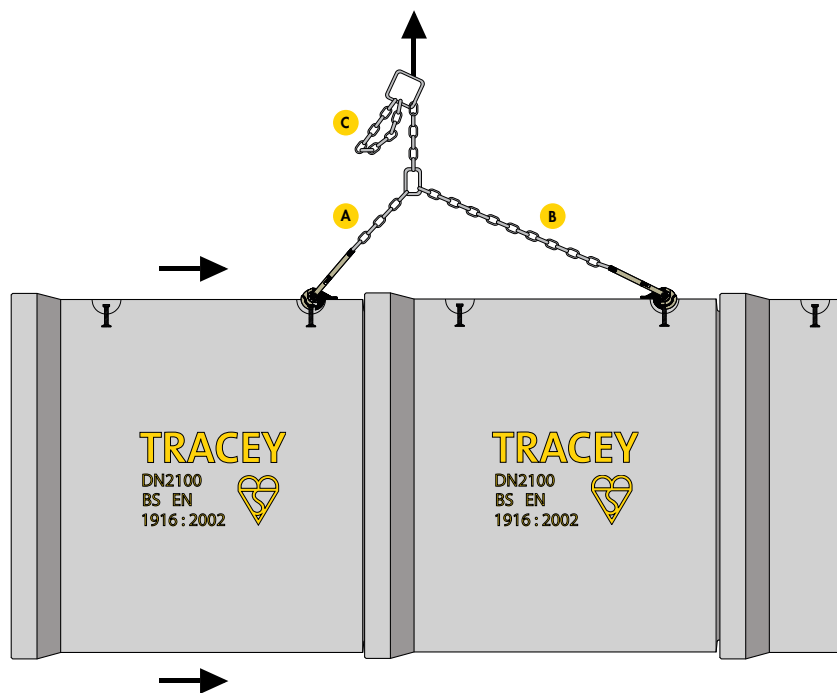

PERFECT BASE™

DN1200, 1500, 1800 & 2100

The Tracey Concrete Perfect Base™ is a custom-made watertight monolithic benched concrete base.

The Perfect Base™ allows Tracey Concrete to manufacture any practical channel inlet/outlet configuration. Inlets are possible at every angle from 90 degrees to 270 degrees from outlet.

The extra flexibility of the Perfect Base™ therefore allows for bespoke base design.

All Perfect bases™ are individual, custom-made to exact site requirements.

Tracey Concrete's large production facilities allow for swift manufacture & delivery to site just days after order.

- Fast Installation
- Safe Installation
- Economical
- Available in DN1200,1500,1800 & 2100mm
- Any Inlet/Outlet Angle
- Complete Take-off Service
- Wide Wall - No concrete surround required
- No on-site benching needed
- Less exposure to silica dust - No cutting inlets/rings
- BSI Kitemarked



PERFECT BASE™

DN1200, 1500, 1800 & 2100

Perfect Base™ – The Future of Manhole Construction

■ **Every Angle:**

Each Perfect Base™ can be manufactured with **limitless channel configurations**

■ **Safer Installation:**

Reduced working time in confined spaces/excavation

■ **Watertight System:**

The combination of a thicker wall and rubber joint ensures a watertight structure

■ **Efficiency:**

Installation times significantly shorter than traditional methods

■ **Design Life:**

120 years

■ **Quality:**

Complies with BS EN 1917 and BS 5911-3
Accepted by major water companies and is included in Sewers for Adoption

■ **Custom Connections:**

Manufactured with integrated couplers to suit any pipe type

■ **Take-off Service:**

Bases manufactured to CAD site drawings

■ **Simple Installation:**

Certified lifting shackles can be provided for safe and easy installation

■ **Low Carbon Footprint:**

40-45% more environmentally friendly than traditional methods

■ **Access:**

Double steps or ladder rungs available

■ **Custom Design:**

Available with custom inlet/outlet & crown/invert configuration



DN1200 PERFECT BASE™ SPECIFICATIONS

DN1200 Perfect Base is the ideal solution for housing projects. The flexible design works well with small diameter pipe.

DN 1200 is the most common size of manhole ring. The table below gives the diameter & weight of the Base depending on the size required.

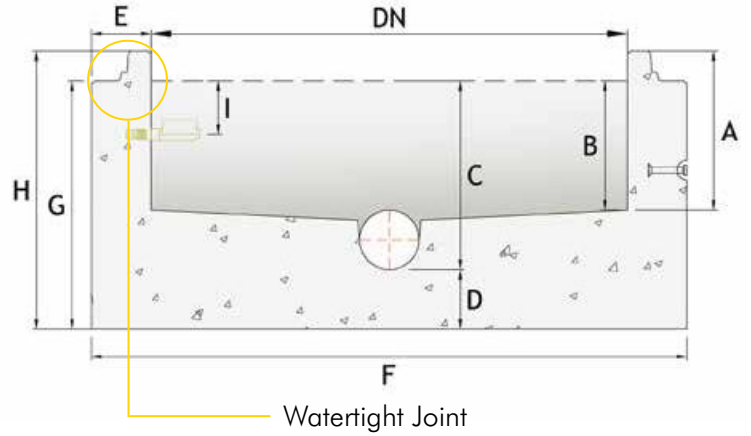

PERFECT BASE / DN1200

Inlet/Outlet Diameter	A	B	C	D	E	F	G	H	I	Approx Weight (KG)
100	400	325	475	150/225	150	1500	625	700	125	1710
100	300	225	375	150/225	150	1500	525	600	125	1550
100	200	125	275	150/225	150	1500	425	500	125	1400
100	100	25	175	150/225	150	1500	325	400	125	1250
150	400	325	475	150/225	150	1500	625	700	125	1710
150	300	225	375	150/225	150	1500	525	600	125	1550
150	200	125	275	150/225	150	1500	425	500	125	1400
150	100	25	175	150/225	150	1500	325	400	125	1250
225	400	325	575	150/225	150	1500	725	800	125	2020
225	300	225	475	150/225	150	1500	625	700	125	1870
225	200	125	375	150/225	150	1500	525	600	125	1710
300	400	325	625	150/225	150	1500	775	850	125	2150
300	300	225	525	150/225	150	1500	675	750	125	2000
300	400	325	625	150/225	190	1580	775	850	125	2450
300	300	225	525	150/225	190	1580	675	750	125	2240
375	400	325	625	150/225	190	1580	775	850	125	2550
375	300	225	525	150/225	190	1580	675	750	125	2750
450	400	325	625	150/225	260	1720	775	850	125	3450
450	300	225	525	150/225	260	1720	675	750	125	3750

Dimensions may vary depending on type of pipe used. Core Height (A) can be adjusted in **50mm intervals**



DN1200 WATERTIGHT MANHOLE RINGS & SLABS

WATERTIGHT MANHOLE RINGS / DN1200

Internal Dia	Depths				Wall Thickness	Overall Dia	Circum	Approx Weight/m	Type of Joint	Lifting Shackles	Step Heights
	mm	250mm	500mm	750mm							
1200	✓	✓	✓	✓	130	1460	4712	1350	Watertight	3 x 2.5T	250

Tracey Concrete watertight manhole rings are manufactured with a watertight joint which is a superior seal to a tongue & groove joint. The 130mm thick wall eliminates the need for a concrete surround, creating an impermeable chamber.



3No **2.5T** Spherical lift shackles are required to lift DN1200 watertight manhole rings and Perfect Base

*Note - Different sizes of spherical lifters are required for each diameter of base



Cast in lifting Anchor

WATERTIGHT MANHOLE COVER SLABS / DN1200

To Suit Internal Dia	Overall Dia	Effective Depth	Approx Weight	Standard Openings Available				
				600 RD	675 SQ	600 SQ	750 SQ	750 x 600
mm	mm	mm	KG	600 RD	675 SQ	600 SQ	750 SQ	750 x 600
1200	1554	230	720	E	E	E/C	E	E

Bespoke openings can be manufactured on request
C = Central Opening E = Eccentric Opening

Tracey Concrete watertight cover slab also has a watertight joint which provides a watertight seal between the cover slab and top MH ring completing the watertight manhole chamber.



3No lifting loops are cast into the cover slab for lifting. A set of equal length 3 leg chains with hooks is recommended



Cast in lifting loop

DN1500 PERFECT BASE™ SPECIFICATIONS

DN1500 Perfect Base is the ideal solution for housing projects. They are typically designed for any type of 375-675 diameter pipes.

The height of DN1500 Perfect Base can be adjusted to suit your specified onsite ground levels. The table below shows the range of heights that can be achieved for each pipe diameter.

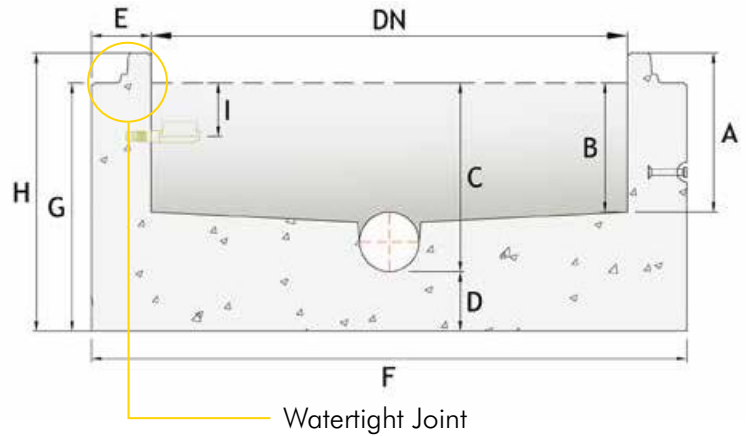

PERFECT BASE / DN1500

Inlet/Outlet Diameter	A	B	C	D	E	F	G	H	I	Approx Weight (KG)
375	500	415	815	200/225	230	1960	1015	1100	175	5000
375	400	315	715	200/225	230	1960	915	1000	175	4700
375	300	215	615	200/225	230	1960	815	900	175	4400
450	500	415	915	200/225	230	1960	1115	1200	175	5390
450	400	315	815	200/225	230	1960	1015	1100	175	5090
450	300	215	715	200/225	230	1960	915	1000	175	4790
450	200	115	615	200/225	230	1960	815	900	175	4490
525	500	415	915	200/225	230	1960	1115	1200	175	5390
525	400	315	815	200/225	230	1960	1015	1100	175	5090
525	300	215	715	200/225	230	1960	915	1000	175	4790
600	500	415	915	200/225	230	1960	1115	1200	175	5390
600	400	315	815	200/225	230	1960	1015	1100	175	5090
675	900	815	1315	200/225	320	2140	1515	1600	175	8050
675	800	715	1215	200/225	320	2140	1415	1500	175	7600

Dimensions may vary depending on type of pipe used. Core Height (A) can be adjusted in 50mm intervals



DN1500 WATERTIGHT MANHOLE RINGS & SLABS

WATERTIGHT MANHOLE RINGS / DN1500

Internal Dia	Depths				Wall Thickness	Overall Dia	Circum	Approx Weight/m	Type of Joint	Lifting Shackles	Step Heights
mm	250mm	500mm	750mm	1000mm	mm	mm	mm	KG	-	-	mm
250	✓	✓	✓	✓	150	1800	5655	1925	Watertight	3 x 5T	250

1500 watertight manhole rings are manufactured with a watertight joint and 130mm thick wall eliminating the need for a concrete surround thus saving time and money.



3No **5T** Spherical lift shackles are required to lift DN1500 watertight manhole rings and Perfect Base

*Note - Different sizes of spherical lifters are required for each diameter of base



Lifting shackle mid lift

WATERTIGHT MANHOLE COVER SLABS / DN1500

To Suit Internal Dia	Overall Dia	Effective Depth	Approx Weight	Standard Openings Available						
mm	mm	mm	KG	600 RD	675 SQ	600 SQ	750 SQ	1200 x 675	750 x 600	*900 x 900
1500	1900	260	1205	E	E	E/C	E	E	E	E

Bespoke openings can be manufactured on request
C = Central Opening E = Eccentric Opening

Tracey Concrete watertight cover slab also has a watertight joint which provides a watertight seal between the cover slab and top MH ring completing the watertight manhole chamber.



3No lifting loops are cast into the cover slab for lifting. A set of equal length 3 leg chains with hooks is recommended

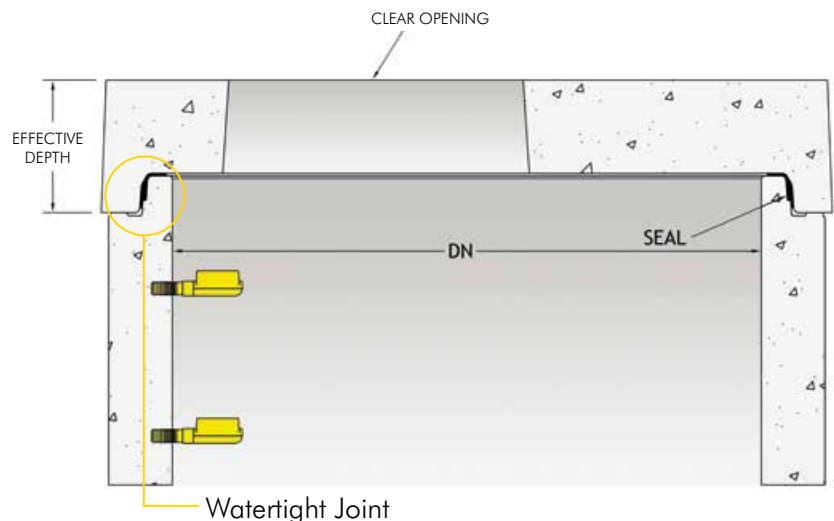

DN1800 WATERTIGHT PERFECT BASE™ SPECIFICATIONS

DN1800 is used for larger diameter storm drainage typically for any pipe material ranging from 675-900mm diameter. DN1800 Perfect Base can also be used in precast concrete attenuation systems.

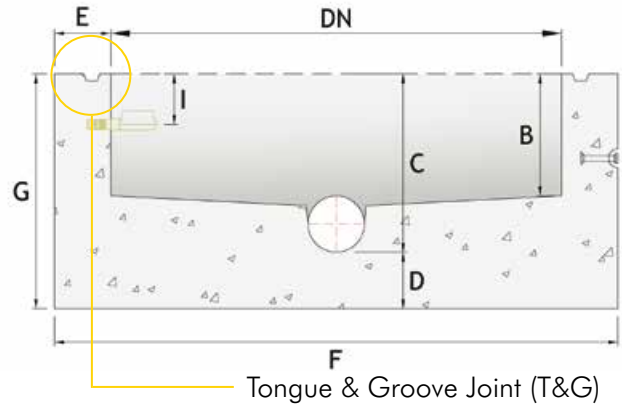

PERFECT BASE / DN1800

Inlet/Outlet Diameter	B	C	D	E	F	G	I	Approx Weight (KG)
675	900	1400	200/225	300	2400	1600	125	10180
675	800	1300	200/225	300	2400	1500	125	9700
675	700	1200	200/225	300	2400	1400	125	9230
675	600	1100	200/225	300	2400	1300	125	8750
750	900	1400	200/225	300	2400	1600	125	9970
750	800	1300	200/225	300	2400	1500	125	9490
750	700	1200	200/225	300	2400	1400	125	9020
750	600	1100	200/225	300	2400	1300	125	8540
900	900	1400	200/225	300	2400	1600	125	9780
900	800	1300	200/225	300	2400	1500	125	9310
900	700	1200	200/225	300	2400	1400	125	8830
1050	900	1400	200/225	300	2400	1600	125	8900

Dimensions may vary depending on type of pipe used. Note: DN1800 Base only available in T&G Option
Smaller diameter pipe may be used with smaller core heights.

Top Tip - reducers can be installed where possible to reduce the weight



DN1800 WATERTIGHT MANHOLE RINGS & SLABS

MANHOLE RINGS / DN1800

Internal Dia	Depths				Wall Thickness	Overall Dia	Circum	Approx Weight/m	Type of Joint	Lifting Holes	Step Heights
	250mm	500mm	750mm	1000mm							
mm	250mm	500mm	750mm	1000mm	mm	mm	mm	KG	-	mm	mm
1800	-	✓	✓	✓	125	2050	6050	1800	T&G	3 x 50mm	250

Tracey Concrete 1800mm manhole rings are manufactured with a T&G joint. The 125mm thick wall eliminates the need for a concrete surround. The chamber is sealed using 120mm x 12mm x 6m con seal jointing bitumen strip.



3No 38mm lifting pins are required to lift DN1800 manhole rings. A waterproof grout will be required to seal each lift hole after install.
3No **10T** Spherical lift shackles to lift Perfect Base

*Note - Different sizes of spherical lifters are required for each diameter of base



Con seal jointing strip

MANHOLE COVER SLABS / DN1800

To Suit Internal Dia	Overall Dia	Effective Depth	Approx Weight	Standard Openings Available						
				600 RD	675 SQ	600 SQ	750 SQ	1200 x 675	750 x 600	*900 x 900
mm	mm	mm	KG	600 RD	675 SQ	600 SQ	750 SQ	1200 x 675	750 x 600	*900 x 900
1800	2050	200	1425	E	E	E/C	E	E	E	E

Bespoke openings can be manufactured on request
C = Central Opening E = Eccentric Opening

Tracey Concrete precast cover slabs come with standard openings as per the table above. Cover slabs with bespoke openings, davit sockets or special finishes can be manufactured on request. Reducing slabs and landings slabs can also be made on request.



3No lifting loops are cast into the cover slab for lifting. A set of equal length 3 leg chains with hooks is recommended



Cast in lifting loops

DN2100 WATERTIGHT PERFECT BASE™ SPECIFICATIONS

DN2100 is used for larger diameter storm drainage typically for any pipe material ranging from 675-900mm diameter. DN2100 Perfect Base can also be used in Precast Concrete attenuation systems

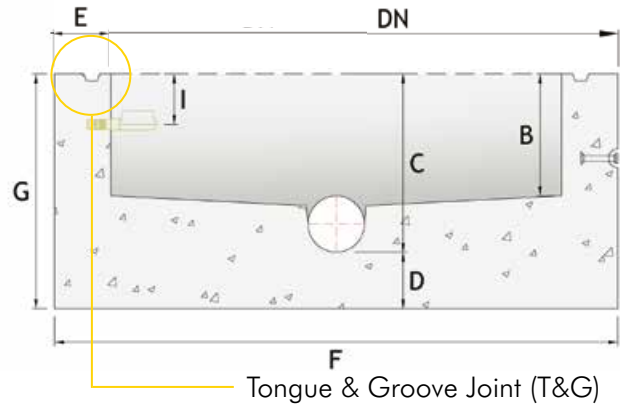

PERFECT BASE / DN2100

Inlet/Outlet Diameter	B	C	D	E	F	G	I	Approx Weight (KG)
675	900	1400	200	300	2400	1600	125	10180
675	800	1300	200	300	2400	1500	125	9700
675	700	1200	200	300	2400	1400	125	9230
675	600	1100	200	300	2400	1300	125	8750
750	900	1400	200	300	2400	1600	125	9970
750	800	1300	200	300	2400	1500	125	9490
750	700	1200	200	300	2400	1400	125	9020
750	600	1100	200	300	2400	1300	125	8540
900	900	1400	200	300	2400	1600	125	9780
900	800	1300	200	300	2400	1500	125	9310
900	700	1200	200	300	2400	1400	125	8830
1050	900	1400	200	300	2400	1600	125	8900

Dimensions may vary depending on type of pipe used. Note: DN1800 Base only available in T&G Option
Smaller diameter pipe may be used with smaller core heights.

Top Tip - reducers can be installed where possible to reduce the weight



DN2100 WATERTIGHT MANHOLE RINGS & SLABS

MANHOLE RINGS / DN2100

Internal Dia	Depths				Wall Thickness	Overall Dia	Circum	Approx Weight/m	Type of Joint	Lifting Holes	Step Heights
	250mm	500mm	750mm	1000mm							
mm	250mm	500mm	750mm	1000mm	mm	mm	mm	KG	-	mm	mm
2100	-	✓	✓	✓	140	2380	7050	2400	T&G	3 x 50mm	250

Tracey Concrete DN2100 manhole rings are manufactured with a T&G joint. The 140mm thick wall eliminates the need for a concrete surround, creating an impermeable chamber.



3No 38mm lifting pins are required to lift DN2100 manhole rings. A waterproof grout will be required to seal each lift hole after install.
3No **10T** Spherical lift shackles to lift Perfect Base

*Note - Different sizes of spherical lifters are required for each diameter of base



Conseal jointing strip

MANHOLE COVER SLABS / DN2100

To Suit Internal Dia	Overall Dia	Effective Depth	Approx Weight	Standard Openings Available						
				600 SQ	600 RD	675 SQ	750 SQ	1200 x 675	750 x 600	*900 x 900
mm	mm	mm	KG	600 SQ	600 RD	675 SQ	750 SQ	1200 x 675	750 x 600	*900 x 900
2100	2375	200	1990	E	E	E	E	E	E	E

Bespoke openings can be manufactured on request
C = Central Opening E = Eccentric Opening

DN2100 Cover slabs come also in a range of standard openings shown in the table above. Cover slabs with bespoke openings, davit sockets or special finishes can be manufactured on request. Reducing slabs and landings slabs can also be made on request.



3No lifting loops are cast into the cover slab for lifting. A set of equal length 3 leg chains with hooks is recommended



Rocker Pipe being installed

STANDARD MANHOLE RINGS

DN900 - 4000

Tracey Concrete manufactures a wide range of Manhole Rings in accordance with I.S. 420: 2004 and I.S. EN 1917 and BS EN 1917, BS 5911-3, BS 5911-4. Manhole Rings are BSI Kitemarked.

MANHOLE RINGS / DN900 - 4000

Internal Dia	Depths				Wall Thickness	Overall Dia	Circum	Approx Weight/m	Type of Joint	Lifting Hole	Step Heights
mm	250mm	500mm	750mm	1000mm	mm	mm	mm	KG	-	-	-
900	✓	✓	✓	✓	70	1040	3050	520	Rebate	3 x 50mm	250mm
1050	✓	✓	✓	✓	85	1220	3550	700	Rebate	3 x 50mm	250mm
1200	✓	✓	✓	✓	100	1400	4050	1050	T&G	3 x 50mm	250mm
1350	✓	✓	✓	✓	100	1550	4550	1100	T&G	3 x 50mm	250mm
1500	-	✓	✓	✓	115	1730	5030	1300	T&G	3 x 50mm	250mm
1800	-	✓	✓	✓	125	2050	6050	1800	T&G	3 x 50mm	250mm
2100	-	✓	✓	✓	140	2380	7050	2400	T&G	3 x 50mm	250mm
2400	-	✓	✓	✓	150	2700	8050	2900	T&G	3 x 50mm	250mm
2700	-	✓	✓	✓	150	3000	9050	3300	T&G	3 x 50mm	250mm
3000	-	✓	✓	✓	180	3360	10000	4500	T&G	4 x 50mm	250mm
3600	-	✓	✓	✓	200	4000	11950	6000	T&G	4 x 50mm	250mm
*4000	-	✓	✓	✓	200	4400	13200	6600	T&G	3 x RD24	250mm



OPTIONS AVAILABLE

- Pre-fitted double steps/ladder steps
- Sealant strip in various sizes
- Base cast in option
- Cored holes in various sizes

* DN4000 manhole ring is manufactured in two halves

* DN3600 & DN4000 are outside the scope of the British Standard (Non-Kitemark but comply with all relevant provisions of the European Standard)
All manhole rings are manufactured to ± 25 mm tolerance

STANDARD COVER SLABS DN900 - 4000

Tracey Concrete manufactures a wide range of Cover Slabs in accordance with I.S. EN 1917 and BS EN 1917, BS 5911-3. DN3600 & 4000 Cover Slabs are generally designed in accordance with BS EN 1992-1-1.

COVER SLABS / DN900 - 4000

To Suit Internal Dia	Overall Dia	Effective Depth	Approx Weight	Standard Openings Available						
mm	mm	mm	KG	600 RD	675 SQ	600 SQ	750 SQ	1200 x 675	750 x 600	*900 x 900
900	1275	150	310	-	E	E	-	-	-	-
1050	1280	160	335	E	E	E	C*	-	E	-
1200	1465	160	495	E	E	E/C	C	-	E	E
1350	1630	160	650	E	E	E	C	-	E	E
1500	1765	160	800	E	E	E/C	E	E	E	E
1800	2050	200	1425	E	E	E	E	E	E	E
2100	2375	200	1990	E	E	E	E	E	E	E
2400	2780	225	3160	E	E	E	E	E	E	E
2700	3005	225	3735	E	E	E	E	E	E	E
3000	3400	300	6470	E	E	E	E	E	E	E
3600	4000	300	9085	E	E	E	E	E	E	E
**4000	4500	300	11590	E	E	E	E	E	E	E

Bespoke openings can be manufactured on request (including double openings)

C = Central Opening E = Eccentric Opening



OPTIONS AVAILABLE

- Special slabs & opening sizes on request
- Full drawing designs and calculations provided
- Reducing Slabs and landing slabs available
- Davitt sockets available on request

Some larger and bespoke slabs DN2100 - 4000 are manufactured hexagonal

*DN1050 Cover Slabs are available in 750Sq in 1465 overall Dia

**4000 slabs are manufactured in 2 pieces

ALL PIPE TYPES - CAST IN

Using our Perfect Base system of casting collars to suit the pipe type specified on the project results in a much more efficient install. No 3rd party adaptors are required and ground-workers can be assured of a sealed joint. We can install any collar to suit such as concrete, twin-wall, PVC, sewer, clay & cast iron.



Tracey Concrete can supply both:
SN8 - Pipe for foul & SN4 - Pipe for storm

See below some of the sample images during installation on-site exhibiting the wide range of pipes spec we have supplied with our Perfect Base System.

- Any Pipe type cast in
- The exact seal from the manufacturer
- No wasted time with make shift adaptors
- Exact pipe as used on-site
- Pipeline fall built into base at inlet & outlet
- Multiple pipe types per base



ADJUSTABLE BASE HEIGHTS

Tracey Concrete can adjust the core height of each base to ensure cover level is met easily on-site. During the drainage take off our engineers will adjust the core height in intervals of **50mm** to suit each individual manhole chamber therefore no cutting of rings onsite is required.

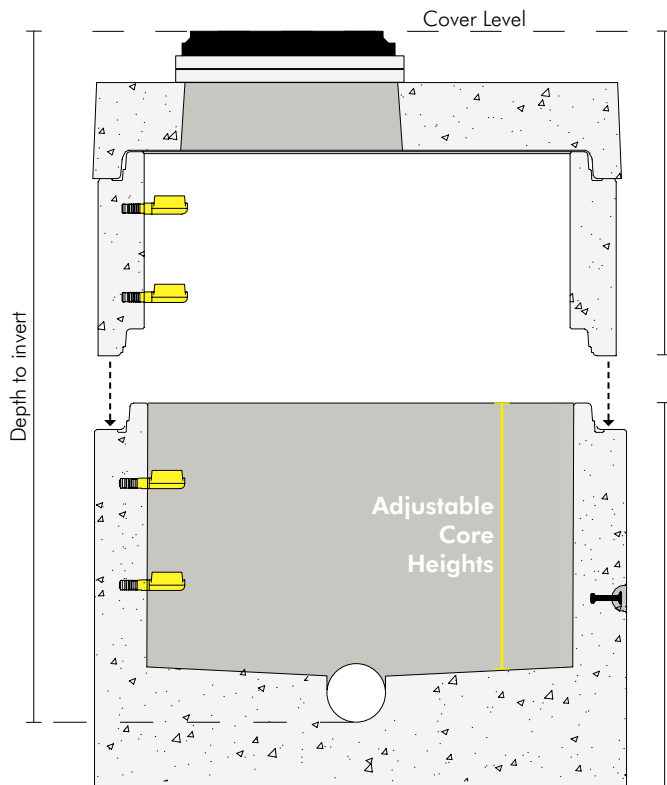

Same Perfect Base™ - Different core heights

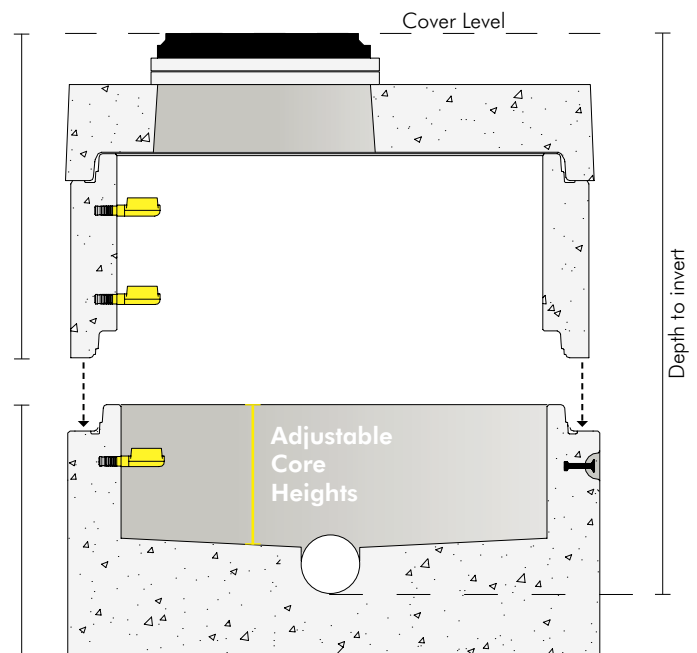

The example above shows 2 chambers with different depths to invert level by adjusting the core height the cover level is met in each base.

Tracey Concrete engineers design each individual manhole chamber to reach the desired cover level. With traditional methods often manholes rings would have to be cut horizontally with a concrete saw exposing the workers to silica dust for long periods of time.

With the Perfect Base™ off site solution there is no cutting and no exposure to silica dust. In certain shallow manhole chambers the perfect base can be designed and manufactured without need for a manhole ring.



HOW IT WORKS - TAKE OFF

Our team of engineers will complete a full drainage take off from your project's AutoCAD / PDF drawings. To build the base digitally for manufacture they require the following information:

- Pipe type
- Inlet & Outlet angles
- Cover level
- Invert level
- Cover slab openings
- Seating Slabs

All the bases are exported to PDF where we can send it back to you for approval.

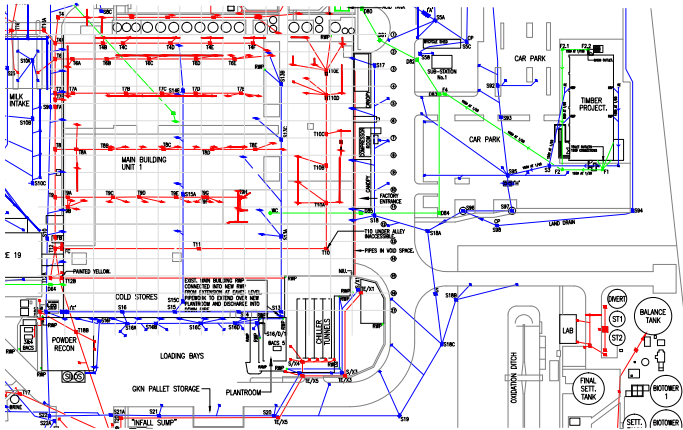

Autocad drawings

Manhole		No. of Outlets	No. of Inlets	Cover Level	Invert Level	Depth to Invert	M/N Size	Care Height	Pipe Size	Depth for Rings - SS	M/N Rings				Total	Height DPT	Ladder Required	Nr of steps/ Ladder rings
											150	150	150	150				
F27	1	2		54.050	48.150	4.931	1200	300	150	385	2	1	1	4	4000	1		10
F28	1	1		53.050	48.424	3.626	1200	250	150	275	2	1	1	2	2750	1		11
F29	1	2		52.000	47.868	3.421	1200	300	150	325	2	1	1	1	2320	1		8
F31	1	2		53.300	47.522	2.778	1200	400	150	175	2	1	1	1	1750	1		7
F44	1	2		50.000	47.000	3.000	1200	300	150	225	2	1	1	1	2250	4		9
F45	1	1		50.500	47.024	3.026	1200	300	150	231	2	1	1	1	2310	1		8
F46	1	1		50.050	46.579	3.071	1200	300	150	226	2	1	1	1	2260	1		9
F47	1	1		49.750	46.664	2.807	1200	250	150	201	2	1	1	1	2000	1		8
F48	1	1		49.000	46.777	2.223	1200	300	150	183	2	1	1	1	2000	1		8
F49	1	1		49.480	46.664	2.796	1200	400	150	175	2	1	1	1	1750	1		7
F50	1	3		50.000	47.000	2.200	1200	300	150	125	2	1	1	1	1250	1		5
F51	1	1		49.700	47.261	2.439	1200	300	150	149	2	1	1	1	1500	4		8
F52	1	2		49.300	46.718	2.582	1200	300	150	177	2	1	1	1	1750	1		7
F53	1	2		49.100	46.579	2.571	1200	400	150	126	2	1	1	1	1500	2		6
F54	1	1		49.300	46.516	2.584	1200	300	150	173	2	1	1	1	1750	1		7
F55	1	3		48.300	45.607	2.503	1200	250	150	227	2	1	1	1	1500	5		6
F56	1	1		48.000	46.100	2.440	1200	300	150	174	2	1	1	1	1750	5		7
F57	1	2		48.300	46.851	2.449	1200	200	225	150	2	1	1	1	1900	4		6
F71	1	2		48.200	46.486	2.344	1200	250	225	170	2	1	1	1	1750	1		7
F72	1	1		48.300	47.730	2.120	1200	300	150	125	2	1	1	1	1250	2		5
F73	1	1		49.400	47.211	2.229	1200	300	150	144	2	1	1	1	1250	1		7
F74	1	2		49.000	47.400	2.000	1200	300	150	125	2	1	1	1	1250	1		5
F75	1	2		49.300	46.721	2.579	1200	300	150	174	2	1	1	1	1750	1		7
F76	1	1		48.400	45.950	2.571	1200	300	150	146	2	1	1	1	1500	1		6
F77	1	1		48.100	46.579	2.571	1200	300	150	175	2	1	1	1	1750	1		7
F78	1	1		48.000	45.404	2.596	1200	300	150	176	2	1	1	1	1750	2		7
F79	1	1		49.100	48.266	1.384	1200	150	150	48	2	1	1	1	500	1		2
F74	1	1		49.100	47.585	1.515	1200	300	150	120	2	1	1	1	1200	2		2
S27	1	2		54.000	49.642	4.328	1200	600	325	278	2	1	2	2	2750	3		11
S28	1	1		52.000	48.866	3.154	1200	600	325	150	2	1	1	1	1500	4		6
S30	1	2		51.100	48.402	2.748	1200	700	325	98	3	1	1	1	1000	2		4
S31	1	1		50.300	47.888	2.402	1200	700	300	227	2	1	1	1	750	1		3
S44	1	2		50.300	47.500	2.400	1200	300	400	95	2	1	1	1	1000	1		3

Takeoff Table

PDF APPROVAL - ORDER

Customer: SISK
Order: Cente Parcs
Date of Order: 07/05/19



TRACEY
CONCRETE

Designation: FW2

- 1 DN / Core Height: 1200mm /475mm
- 2 Weight: 1669 KG
- 3 Spigot Type: Watertight
- 4 Pipe Type: Shown on base diagram
- 5 Chamber Buildup: -1No 1200 x 1000 wt ring
-1No1200 Slab 675sq - 2No Seating Slabs 675sq

- 1 Check diameter
- 2 Check weight - machine onsite capable of this lift?
- 3 Check spigot/ joint type
- 4 Check pipe type
- 5 Check build up of the chamber
- 6 Check inlet locations and sizes

Approved for Production **Yes** **No**
Sign & Dated John Smith - 08/05/2021
Customer O/N 12302-12 Internal O/N 1012340

All approved perfect bases will be invoiced no later than 30 days after production, regardless of delivery status.
Please request a copy of our Terms and conditions for full details

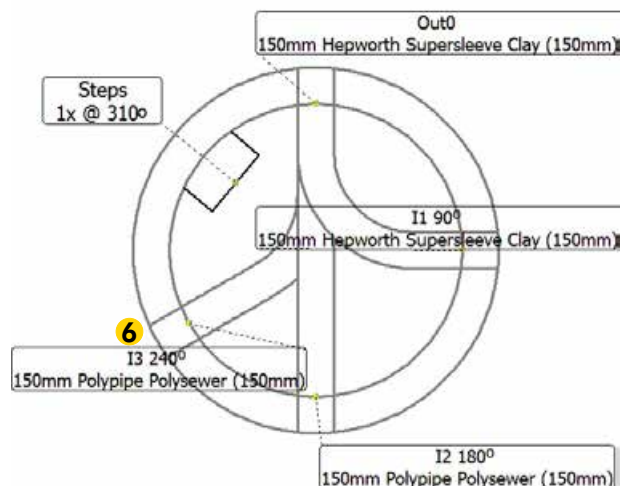

The PDF will contain all the Perfect Bases from the take-off showing the layout of each base before production. We recommend that the contractor have their engineer proof each base with his drainage plans before signing off for manufacture.

PRODUCTION

The customers bases are then put into production on the agreed lead time. Using recycled polystyrene we cut the angles for each individual base, which form the channels, inlets & outlets. Within 24 hours the bases are stripped from the mould and put into a curing area. The bases are picked by our loading team when ready for despatch.

Top Tip- Provide us with the dates and order you require your bases so we can have your Priority bases onsite.



 Watch how Perfect Bases are made via this QR code



DELIVERY TO SITE

Our despatch co - ordinator will contact you to let you know when your delivery will arrive. You will also receive a text message and email notification (optional). If required, we can offload the products using a lorry mounted crane. However larger bases such as DN1500, 1800, & 2100 bases will need to be offloaded by a machine on-site.

Please see lifting equipment on our website All lifting equipment for can be supplied by Tracey Concrete. Please let our team know of any site specific requirements: opening times, site contacts and site traffic plans.



THE SEAL

Trelleborg 116 is designed as a sliding seal to which lubricant has been applied between the sliding skin and the body of the seal. The tip of the skin is folded over and glued to the body of the seal to ensure the lubricant stays in place. Link to data sheet <https://bit.ly/2YXL8bq>

During installation, the adhesive joint releases allowing the lubricated skin to slide over the body of the seal.

This design permits installation with very low force, as there is no friction between rubber and concrete. The special design of the joint and seal make the system easy to centre during jointing.

- Installation with very low force
- Pre Lubricated seal for manhole System
- Easy to centre during jointing
- Water tested 0.5 Bar

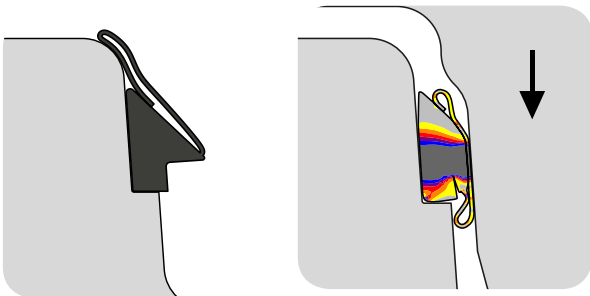
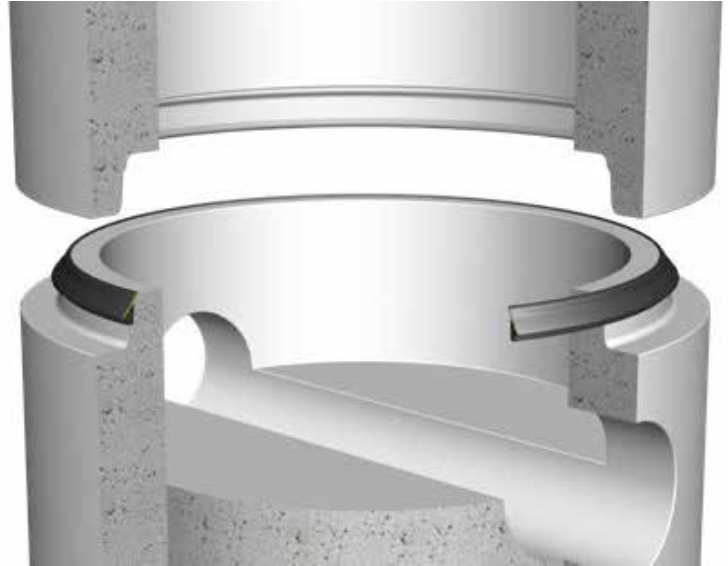

The flat side of the seal sits on the shoulder of the ring. When the next ring is installed the outside of the seal slides down and seals the joint as shown.



QUALITY & TESTING

Material & aggregate testing is an essential to produce a high quality precast concrete product. At Tracey Concrete we carry out numerous tests on our materials every day to ensure they are of the highest quality. As a manufacturer we are constantly striving to improve our products to ensure they are of industry leading standard.



Slump test - Test moisture content of drycast concrete



Flow test - Test moisture of self compacting concrete



Concrete cubes - curing process before testing



Cube crush - Strength test after 14 & 28 days



**3No
watertight
seals**



A sample watertight test carried out at our production facility. On the left you can see the complete chamber and on the right an image of the top of the cover slab showing the chamber full with water.

PERFECT BASE INSTALLATION GUIDE

Introduction

This guide offers advice on how to install the Tracey Concrete Perfect Base system incorporating a watertight elastomeric seal known as a 'Perfect sealed manhole' system. The system provides a manhole whereby all joints and connections have elastomeric seals enabling a watertight manhole to be constructed quickly and easily with the minimum of site work.



Manholes are consequently installed in a similar manner to pipes requiring a different technique to traditional manhole construction

The wall thickness being over **125mm**, means that the installed manhole does not require a concrete surround unless specified by the client.

The Perfect Base complies with ISEN 1917:2002 and IS420 and is kite marked to BS EN 1917 and BS 5911-3 and the 1200 diameter Perfect manhole is CE marked Components

Components

A Perfect Base system will typically comprise of a combination of the following standard elements. Perfect Base units shall comprise of the following:

1. Chamber unit depth dependant on manhole diameter and channel diameter
2. The base depth varies to obtain correct overall height
3. Integral base to give a watertight unit
4. Channel and benching pre-formed to exact requirements
5. Formed holes for jointing to inlet/outlet pipes and seals
6. Shaft unit with spigot and socket joint with the seal fitted
7. Watertight Cover slab with specified opening

*The integrated ladder system is also available with the sealed manhole system Cover Slab

**Manholes & Base can be supplied with or without double steps

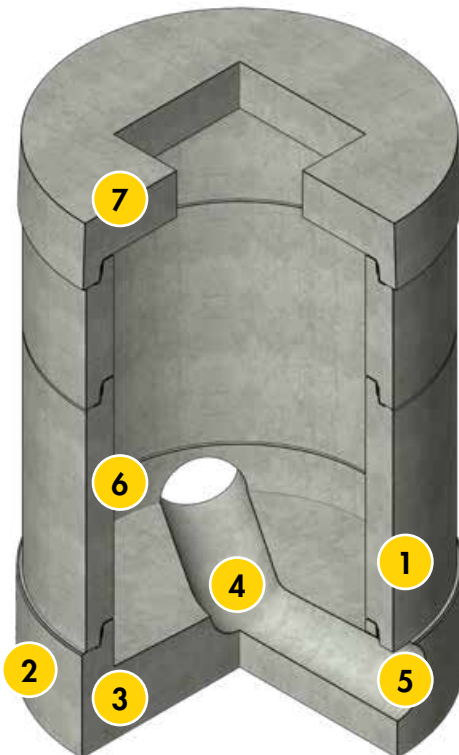

PERFECT BASE INSTALLATION GUIDE

Off-loading and lifting

All Tracey Concrete Perfect Bases are manufactured with spherical lift head anchors cast in. The lift head shackle should be fitted in accordance with the manufacturers recommendations with the extended tab pointed in the direction of the lift. Both 2.5, 5 & 10 tonne lift head shackles can be supplied by Tracey Concrete

We recommend that each shackle should be lifted with a suitably rated duplex web sling or chain. Each Base has 3 lifting anchors cast in so 3No Shackles are required for lifting & installation.



lifting angle
for chains
should be
 $\geq 45^\circ$



Top Tip - The perfect sticker informs you of what you require to complete manhole

Assembly

Normal considerations should be taking into account when assessing the suitability of the formation. In good ground conditions manhole can be built off either;

- Minimum 150mm pipe granular bedding material being 5-20 graded, 14, 20, 40mm single size suitably compacted to provide a level base.

- 150mm GEN 1(C8/10) concrete. Base unit should be placed whilst concrete is wet so it can be set level otherwise a levelling screed of 15-20 mm sand cement will be required to prevent point loading on the base unit

Note: In poor or wet ground conditions a concrete pad is advised. Normally a granular bedding is recommended where the safe ground bearing pressure $>200\text{kN/m}^2$



Top Tip - Clean inlets and outlet of any debris

PERFECT BASE INSTALLATION GUIDE

Seal Installation

The seal is ideally positioned on the base unit before it is in the excavation in the following manner

1. Stretch the seal onto the spigot of the manhole and position it against the shoulder. Make sure the load distributor (the circular part) is located on the upper surface of the spigot
2. Check the internally lubricated skin is correctly positioned and sitting against the rest shoulder
3. Equalise the stretch in the seal by lifting at several points

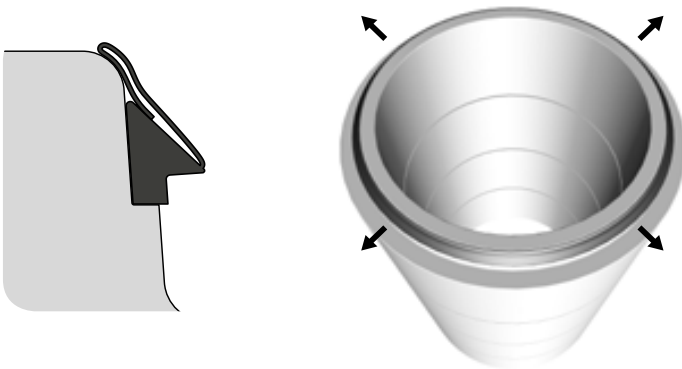

Note: External lubrication is not required



Shaft Construction

Once the bedding has been prepared, the base unit can be positioned. It is advisable to lay the pipeline up to and including the rocker pipe on the downstream side. A short length of pipe should then be inserted into the outlet pipe seal on the base unit. This acts as the 'butt' pipe

Note: The butt pipe is not strictly required as the joint within the manhole wall acts as a flexible joint

The unit can then be jointed with the rocker pipe as it is finally positioned in the excavation. A final level check should be carried out.

Top Tips

- The perfect sticker has all information to complete manhole
- Install/ fit the Rubber Seals in advance - 2 men
- Clean inlets and outlet of any debris
- Store lifting shackles & seals in a safe place
- Install/ fit rocker or double spigot before lifting into trench

PERFECT BASE INSTALLATION GUIDE

Backfilling

The base unit can be backfilled with a granular pipe bedding around the pipes and suitable material around the shaft. The remainder of the shaft can then be constructed by centring the upper manhole section, and lowering into place. The design of the joint encourages 'self-centring'. For ease of installing it advisable to backfill the shaft as it is built. This provides ease of access to unhook the lift clutches and to guide the units into position.

A joint gap between 10-20mm should be obtained after jointing, this gap may reduce as the shaft is constructed dependant on the depth to the minimum 10mm. The cover slab can be laid again using the lifting system. The slab may need slight vertical downward pressure to seal the unit as the self-weight may not always be sufficient.

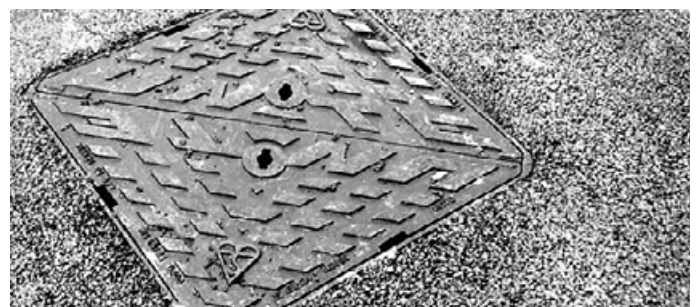
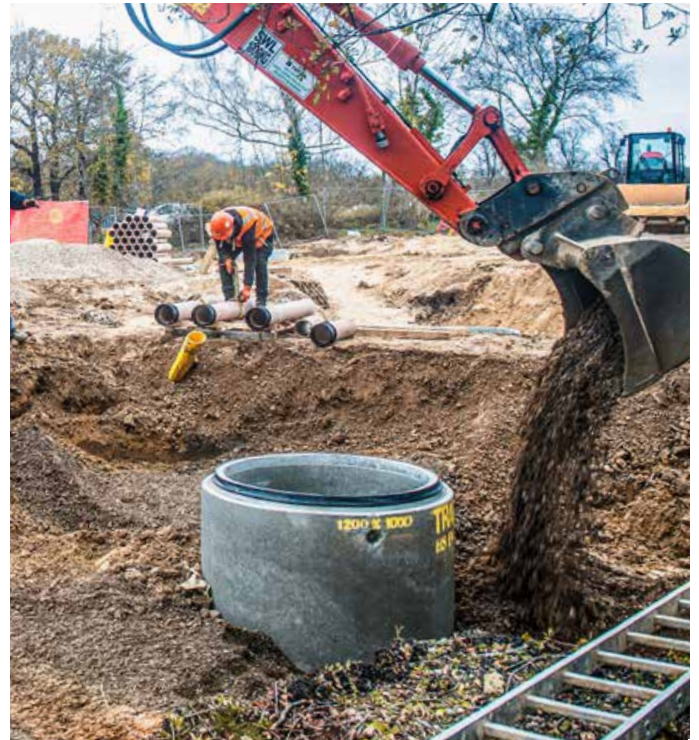





THE PERFECT STICKER

Each Perfect Base is labelled with a bespoke sticker showing important information for installation. All installation details on the sticker on the base. From the take off we state on the sticker what products are required to get to cover level.

Unique Base code to match plans

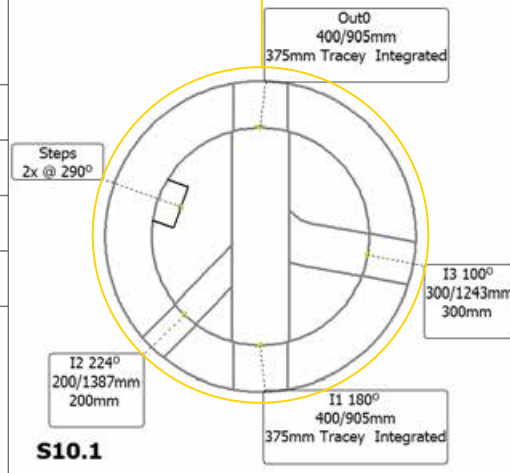
Base layout shows channels & inlets/outlets

<p>Tracey Concrete Limited Old Rossory, Sligo Road BT74 7LF-Enniskillen, Co. Fermanagh www.traceyconcrete.com headoffice@traceyconcrete.com www.perfectsystem.eu Tel. 028 6632 6437 Fax. 028 6632 4908</p>	  	
Customer:	Sisk	
Order:	Centre Parks	
Designation:	S10.1	
Date of order:	04/03/2019	
DN / height:	1500mm / 915mm	
Weight:	5843kg	
Concrete quality:		
	<p>Remark: NOTE: LIFTING HOOK SET @ 60 DEG MINIMUM. W/T JOINT. 225mm smooth wall sewer. 375mm Tracey Concrete Pipe. ADD: -1No 1500x1000 WT -1No 1500x500 WT -1No 1500 C/S WT -2No 600 SEATING SLABS -1No 600 H/D LID</p>	

Products required to reach cover level



ANY FALL OPTIONS - PAN TILT

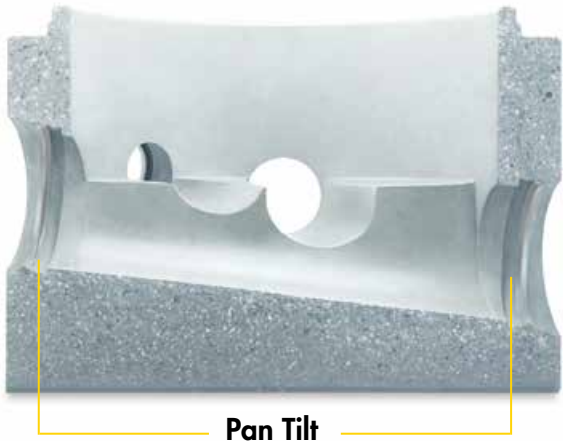

With the Perfect Base system we design and manufacture the gradient of the pipe into the base by adjusting the pan tilt of the inlets/outlet.

This simplifies installation when connecting the rocker pipes or double spigots pipes to the base as they are set at the correct fall. E.g. matching the gradient of the pipeline specified on the project and leaving pipe installation easier.

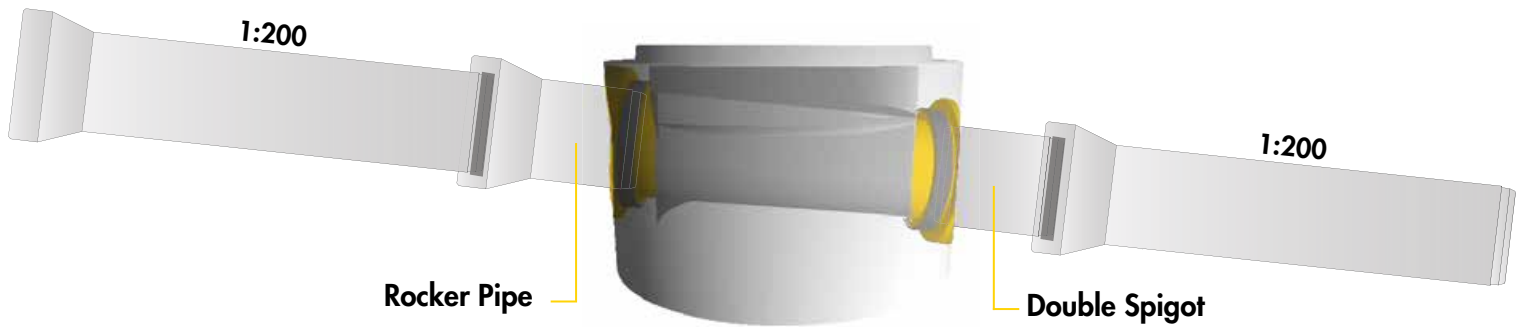

PERFECT BASE VS TRADITIONAL

With the Perfect Base there is no wasted time spent laying pipes, to form channels, no part load of readymix to form insitu base and no need to concrete jacket the chamber.

Simply drop in the Perfect Base, fit pipes to inlets & outlet and complete installation by fitting manhole rings and slab. This process saves significant amount of time and is much safer.

Traditional



Perfect Base

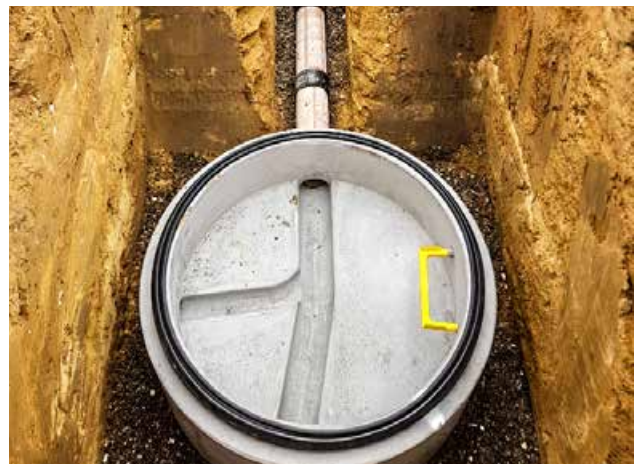

CONCRETE PIPE CONNECTION OPTIONS

When connecting the Perfect Base with precast concrete pipe there are some different options. A double spigot pipe & rocker pipe can be used with the same sealing system as in the pipe.

Another option is to use butt end spigot & socket pipe which is a pipe cut at the end with no joint. This method can be used on-site to ensure there is no creepage in the pipeline and causing a manhole to be out of position. To seal butt pipes a Forsheda 910 seal is cast into the base with no joint.

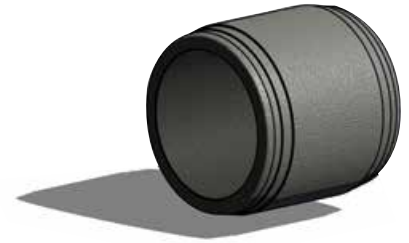

Double Spigot
DN225 - 1050



Rocker Pipe
DN225 - 2100



Spigot Butt Pipe
DN225 - 2100



Socket Butt Pipe
DN225 - 2100



Rocker Pipe being connected to a Perfect Base™



Double Spigot Pipe connected into a Perfect Base™

COMPLETE WATERTIGHT CHAMBER

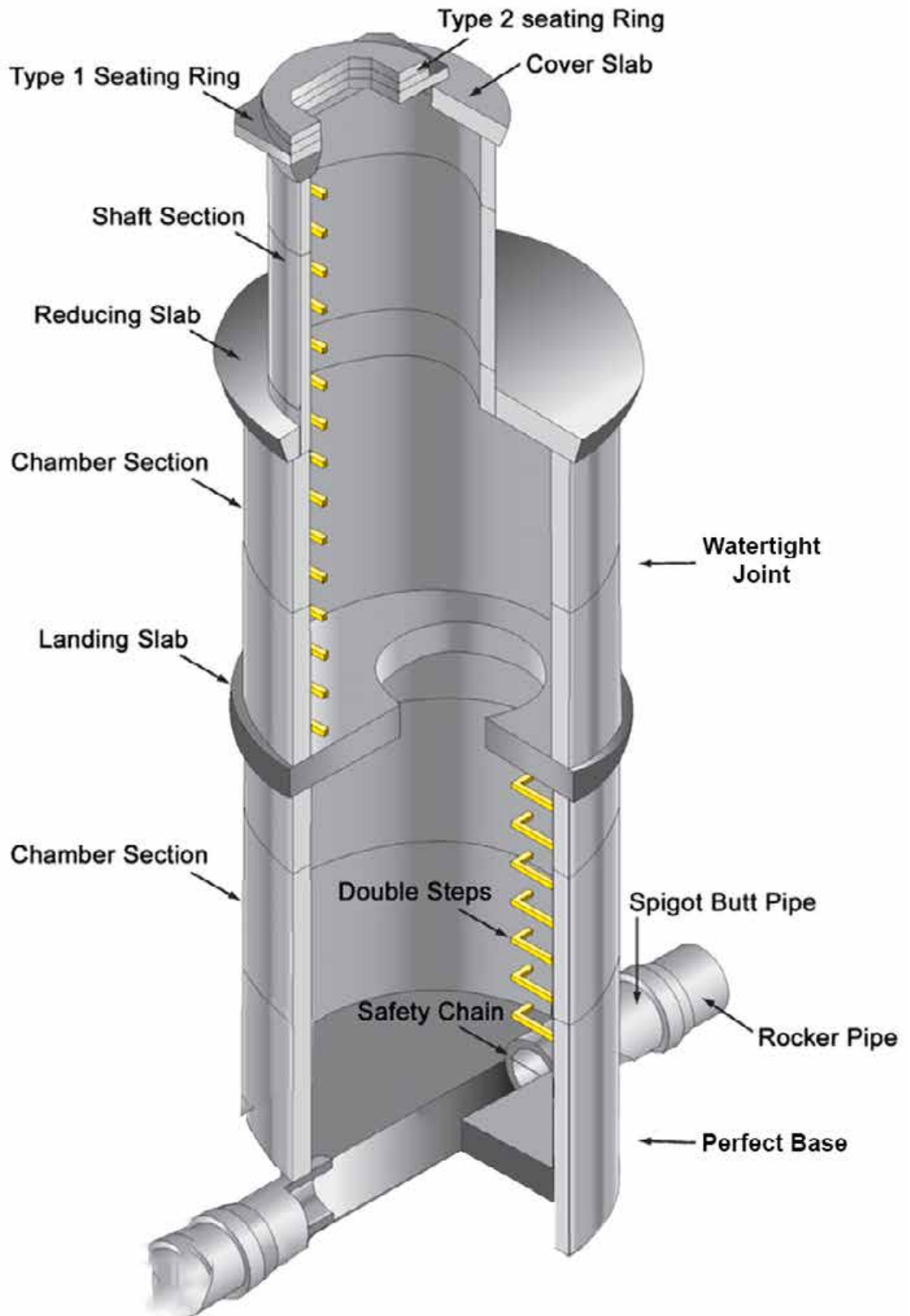

FLOW CONTROL CHAMBERS

A Flow Control Chamber combines an integral base and side walls with option for inlet and outlet openings/connections. A Flow Control Chamber can be used for a silt-trap, valve chamber and can be used as a flow rate controller (requires installation of a vortex or orifice valve unit)

Tracey Concrete can offer supply of a vortex or orifice valve device. The vortex or orifice valve is designed to limit storm water outflow to a specific discharge rate. Sizes are available between 1–80 l/s depending on head height. .

Hydro-Valve fits the following manhole types:

Chamber Size	DN1050	DN1200	DN1350	DN1500	DN1800	DN2100	2400
Flat back *	✓				✓	✓	✓
Curved back		✓	✓	✓			

*Flat back requires shuttered wall on the inside of the chamber

The unit is self activating with no need for an external power source and comes with a certified flow rate. At low flow rates, water entering through the inlet passes through the vortex chamber to the outlet with no restriction. As flow rate increases, water enters through the inlet with enough energy to create a vortex in the vortex chamber, which results in a considerable pressure drop between the inlet and the outlet restricting the flow to the allowable discharge. The vortex or hydro valve flow control operates automatically with no moving parts and no external power source. A typical application of this valve is to control the flow from storm water attenuation tanks, preventing downstream flooding during periods of heavy rainfall



Flat shuttered wall



Curved wall hydrovalve



PUMPING CHAMBERS

Tracey Concrete can provide a range of precast concrete storage tanks for pumping chambers with either separate or a combined chamber and pipe system.

Using our precast pumping station storage tanks reduces site disruption to both those working onsite and the local community nearby, and as the tanks are made offsite, these are added health and safety benefits.

The precast concrete storage tanks make installation more efficient and cost effective and are available with a range of fittings.

ADVANTAGES

- Immediate watertight structure
- Reduced installation time and costs
- Accommodates connection to all types of pipe
- Easy and clean access for operation and inspection

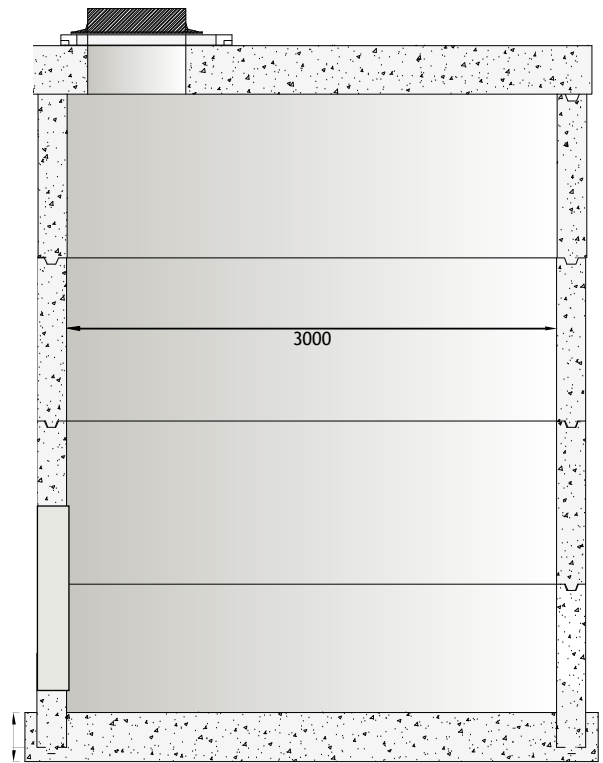

MANHOLE ACCESSORIES

STEPS & LADDER STEPS

Steps can be supplied fitted or loose in all our manhole products. Manufactured to EN 13101: 2002 Type D Class 1 and BS EN 13101. Made with an outer grip to ensure safe movements when inspection is required.

Ladder Steps can also be supplied fitted or loose in all of our manhole products. Manufactured to BS EN 13101. Supplied with rolls of stringer and red caps upon request for manholes deeper than 3m.

A handheld entry pole system is also available, allowing safer access to the fitted steps of the manhole chamber.

Modular Manhole Ladder can be supplied as an alternative to ladder steps. The Modular ladder system has been fully tested to BS 14396 by Lloyds British PLC and is CE marked.

*Installation spec available at www.traceyconcrete.com



Steps Fitted



Ladder Steps with Stringer



JOINTING STRIP & CONSEAL

A wide range of jointing strips (elastomeric jointseal) are available for all sizes of manhole rings made to spec EN681.

Easily installed jointing strip is designed to seal standard manhole chambers fast and efficiently.

Sizes Available	To Suit Manhole Sizes
22mm x 22mm x 4.5m	DN900 - 1500mm
22mm x 44mm x 4.5m	DN1800 - 2400mm
12mm x 120mm x 6m	DN2700 - 4000mm

PRIMER - 5L

Primer is used for priming the joints of precast concrete manholes, inspection chambers prior to the applications of jointing strip.

SOAKAWAY CHAMBERS/PERFORATED RINGS DN900 - 4000

Soakaways are a key component for Sustainable Urban Drainage Systems (SuDS). Soakaways provide a simple way of dealing with storm water locally, by encouraging ground water recharge whilst reducing the impact on the existing storm water network.

SOAKAWAY CHAMBERS / HOLES PER CHAMBER

Size DN	Depths Number of Holes		
	500mm	750mm	1000mm
mm	500mm	750mm	1000mm
900	5	7	9
1050	6	8	11
1200	6	9	12
1350	7	11	14
1500	8	12	15
1800	9	14	18
2100	11	16	21
2400	12	18	24
2700	14	21	27
3000	15	23	27
3600	18	27	36
4000	20	30	40

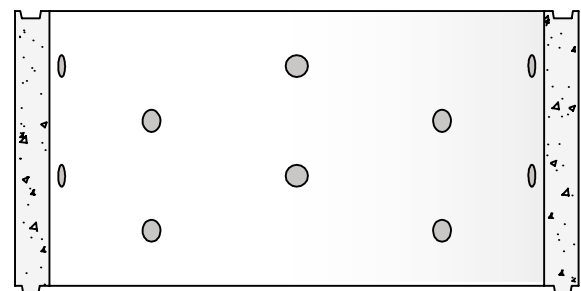
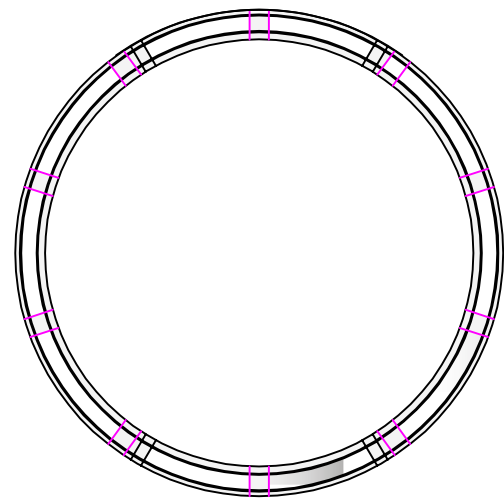

Tracey Concrete produce soakaways in depths of 500mm, 750mm and 1000mm, each containing the correct amount of Ø80mm holes to provide a minimum area of permeation of 50,000mm²/m of nominal diameter per metre of height complying to BS EN 1917:2002 and BS5911-3.



PRECAST INSPECTION CHAMBERS

Tracey Concrete manufacture precast house inspection chambers to suit building regulations Part H and the Irish Water code of practice. These chambers are designed to Irish Water specifications therefore meaning a quick sign-off period. As a precast concrete chamber, they save time as they can be installed fast compared to traditional shuttering.

- Manufactured to suit 100mm PVC pipe.
- 3No RD20 Lifters required for lifting
- Weight: 780kg
- Covers and frames shall be suitable for road and traffic conditions
- Minimum 150mm pipe granular bedding material being 5-20 graded, 14, 20, 40mm single size suitably compacted to provide a level base.



Precast inspection chamber

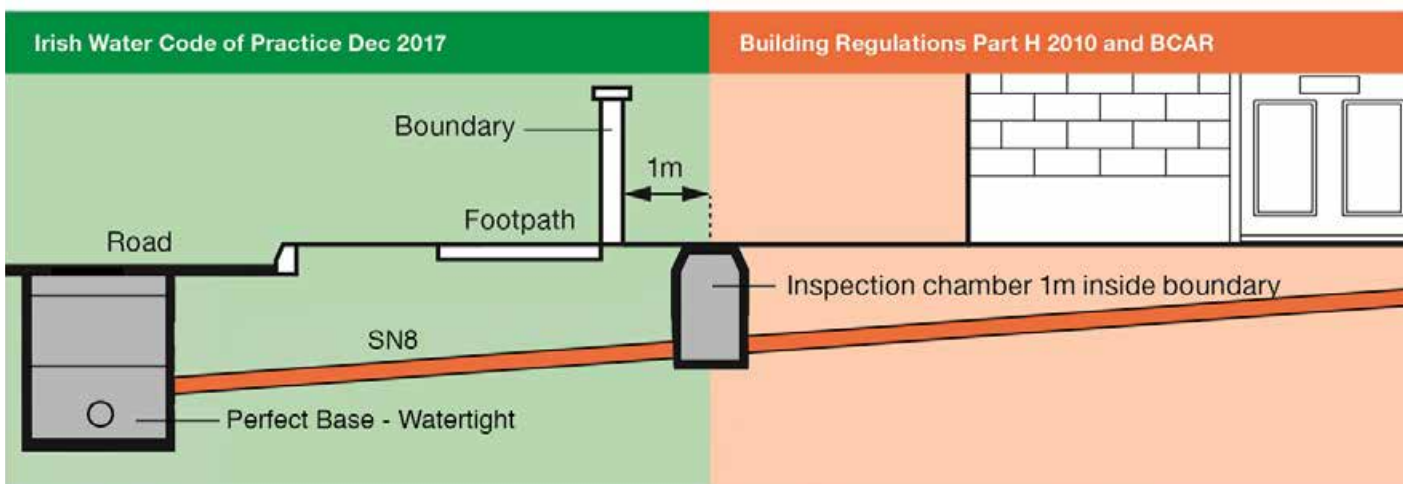
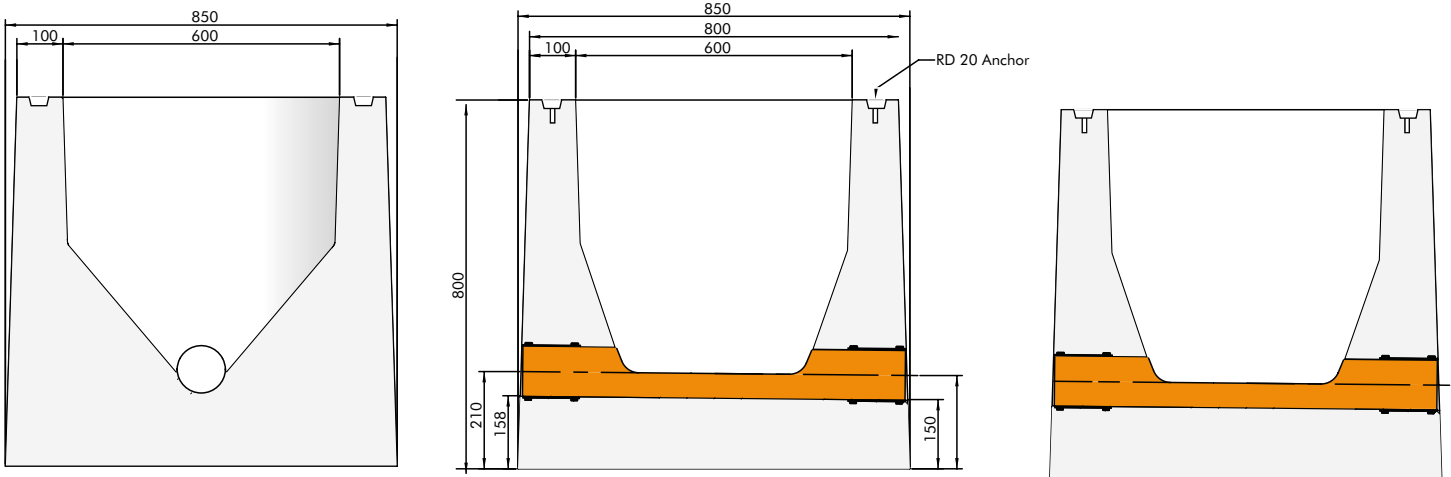

PRECAST INSPECTION CHAMBER RISERS

Tracey Concrete manufacture precast house inspection chamber risers in depths of 150mm & 300mm. Designed with a tongue and groove joint (detail below) they can be installed quickly onsite to get to cover level.

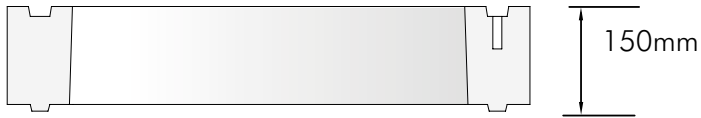

- 3No RD20 Lifters required for lifting
- Weight: 150mm riser 100kg



- 3No RD20 Lifters required for lifting
- Weight: 300mm riser 190kg
- For jointing the chambers and risers we recommend hyperseal 25-lm-s

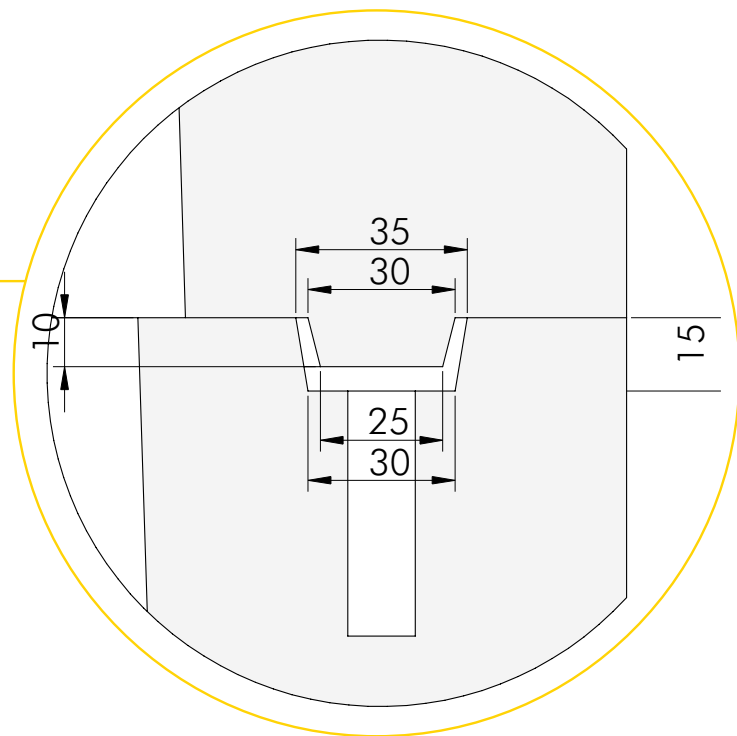
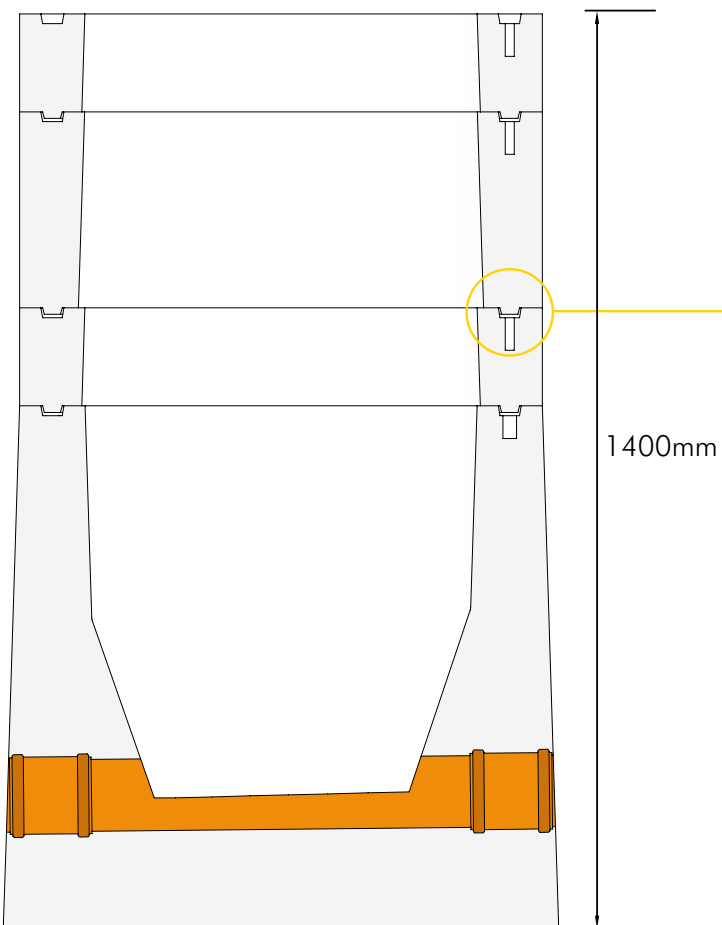

Tongue & groove joint detail

Complete inspection chamber



JUNCTION BOXES

Tracey Concrete manufacture the full range of junction boxes and communication chambers. To see our full range & brochure visit our website www.traceyconcrete.com

FIRE HYDRANT CHAMBERS

Fire Hydrant Chambers consist of a precast concrete chambers are used to protect and house valves and hydrants. They can be installed faster, safer and more efficient than casting insitu onsite.

Lifting equipment:
3 x RD24 Lifters

Approx Weight:
426kg

Mechanical Resistance:
Strength Class C35/40

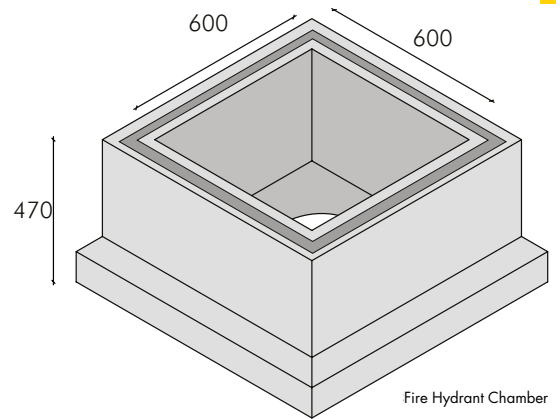

SLUICE VALVE CHAMBERS

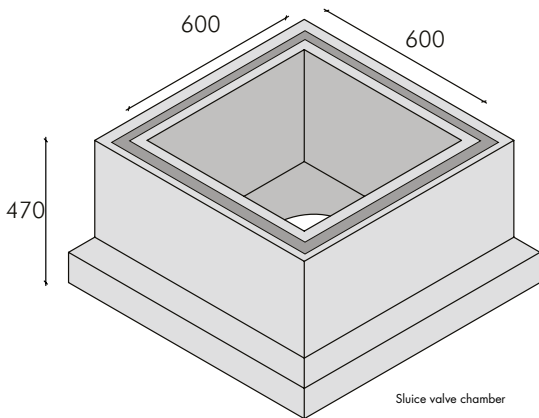

Lifting equipment:
3 x RD24 Lifters

Approx Weight:
426kg

Mechanical Resistance:
Strength Class C35/40

Sluice Valve Chambers are a precast concrete chamber which are used to protect and house valves and hydrants. They can be installed faster, safer and more efficient than casting insitu onsite.

AIR VALVE CHAMBERS

Air Valve Chambers are a precast concrete sealed sump manhole. Made with factory-fitted saddles to house the pump and are used in the management of water, oils and chemicals.

Lifting equipment:
3 x RD24 Lifters

Approx Weight:
515kg

Mechanical Resistance:
Strength Class C35/40

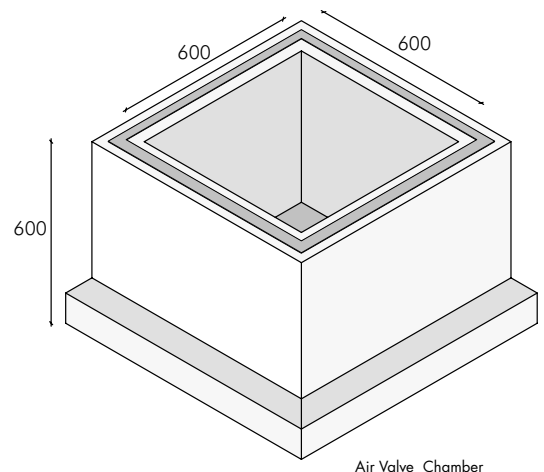

PRECAST ATTENUATION SYSTEMS

Tracey Concrete manufacture and design attenuation water storage systems using our S&S Pipe range offering superior strength than other options on the market. Designed to suit the clients specifications we can manufacture each bespoke system to suit any capacity and area.

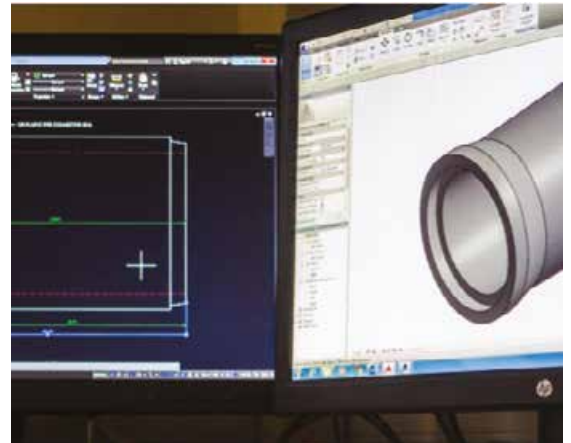
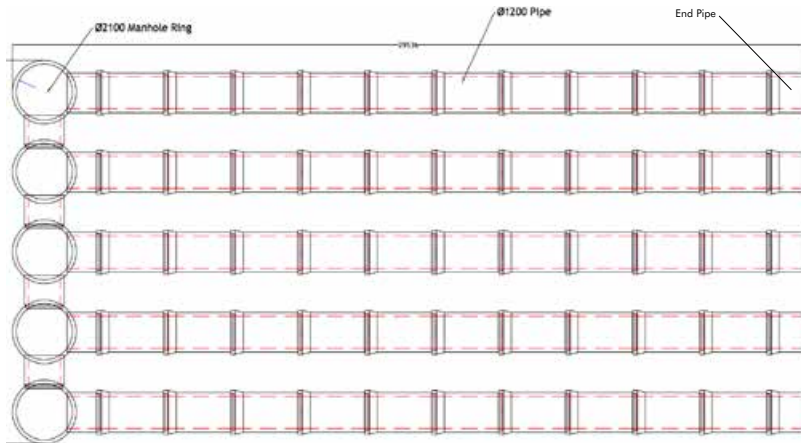

Our concrete attenuation systems can include bespoke products such as stop end bends, side entry manholes and spigot and socket end wall pipes. These products can either be engineered into an on-line sewer pipe system or utilised off-line as single or multiple stormwater holding tanks.

Internal Pipe ø	mm	DN900	DN1050	DN1200	DN1350	DN1500	DN1800	DN2100
Capacity	m ³	1.59	2.16	2.83	3.58	4.42	6.36	8.65

ADVANTAGES

- Systems can be designed to suit the application
- Can be installed under roads and car parks
- No need for fabrication onsite or external contractors
- Long term solution



SEATING SLABS & LOTHIAN SLABS

Seating Slabs are designed to be fitted on top of the cover slabs and gullies. By fitting our seating slabs the steel cover can quickly be brought up to the cover level required without the need for time to be spent on brickwork. Seating Slabs are manufactured to requirements of BS EN 1917, BS 5911-3.

SEATING & LOTHIAN SLABS

Opening	Depth	Weight	Dimensions
mm	mm	KG	mm
Type 1 600 Square	65	105	1050 x 975
Type 1 675 Square	65	90	1050 x 975
Type 1 600 Round	65	115	1050 x 975
Type 1 675 Round	65	105	1050 x 975
Type 1 1200 x 675	65	135	1575 x 1050
Type 2 600 Square	65	80	1000 Round
Type 2 675 Square	65	70	1050 Round
Type 1 750 x 600	65	86	1050 x 975
Type 1 750 x 750	65	85	1050 x 975
*Lothian Slab - 675 Square	150	292	1155 x 1155

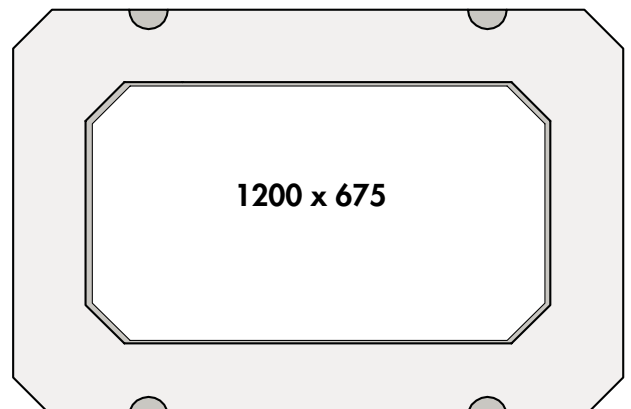
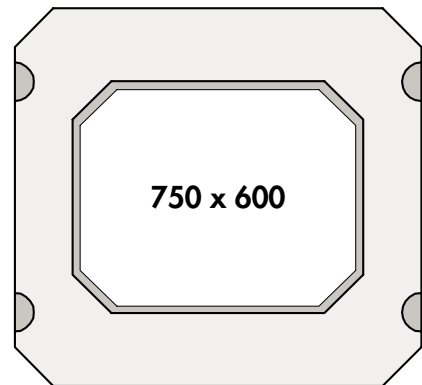
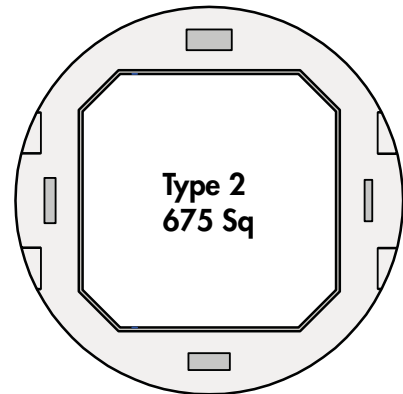
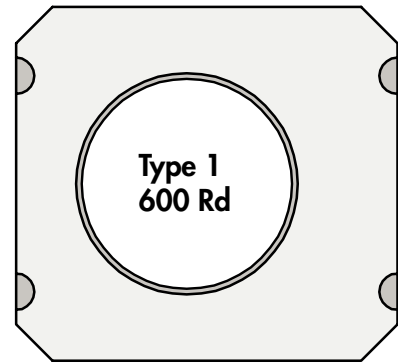
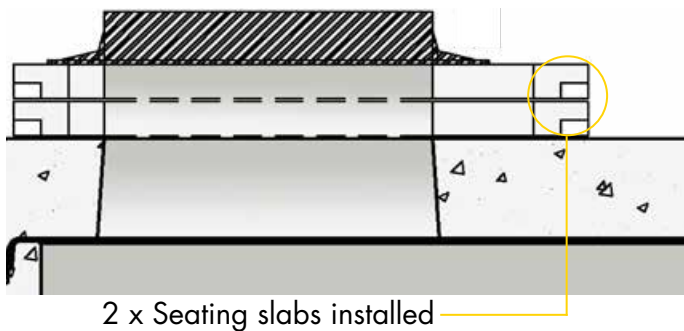

ADVANTAGES

- Designed to replace engineering bricks
- Simple & fast installation
- Compressive strength equal to Class B engineering brick
- More cost effective than brickwork

GULLIES & GULLY SEATING SLABS

375 & 450

Road Gullies are manufactured to BS 5911-6 and are BSI Kitemarked. Gullies are supplied with a seal to suit plastic (Forsheda 207 x 20.5) or densleeve (Forsheda 201 x 13).

TRAPPED & UNTRAPPED GULLIES / 375 & 450

Type	Size (A)	Depth (B)	Approx Weight	Outlet
Trapped / Untrapped	mm	mm	KG	mm
Untrapped	375	750	180	150
Trapped	375	750	200	150
Trapped	450	750	250	150
Trapped	450	900	285	150
Trapped	450	1050	290	150
Gully Seating Slab	750 x 650	100	80	450
Horseshoe Seating Slab	650 x 600	100	44	450

ADVANTAGES

- Seal cast in to prevent onsite damage
- Rodding eye closure recessed into concrete
- Light weight design for lower carbon footprint
- Eliminates discharge of oil
- Gully grating and cover available



Gully Seating Slab

Horseshoe Gully Seating Slab

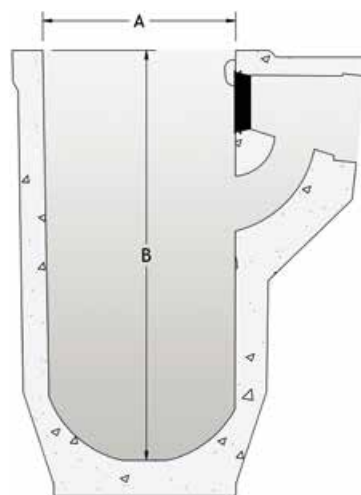

Trapped 450 x 900 Gully



CATCHPITS

DN900 - 3000

A Catchpit is an empty chamber with an inlet pipe and an outlet pipe set at a level above the floor of the pit. Any sediment carried by the system settles within the Catchpit, from where it can be periodically pumped out or removed.

CATCHPITS / DN900 - 3000

Internal Dia*	Depths**	Wall Thickness	Overall Dia	Circum	Approx Weight/m	Type of Joint	Lifting
mm	mm	mm	mm	mm	KG	-	-
900	1000 1250 1500 2000	70	1040	3050	775	Rebate	Lifting Loops cast in
1050	1000 1250 1500 2000	85	1220	3550	1025	Rebate	Lifting Loops cast in
1200	1000 1250 1500 2000	100	1400	4050	1500	T&G	Lifting Loops cast in
1350	1000 1250 1500 2000	100	1550	4550	1650	T&G	Lifting Loops cast in
1500	1000 1250 1500 2000	115	1730	5030	2200	T&G	Lifting Loops cast in
1800	1000 1250 1500 2000	125	2050	6050	3100	T&G	Lifting Loops cast in
2100	1000 1250 1500 2000	140	2380	7050	5000	T&G	Lifting Loops cast in
2400	1000 1250 1500 2000	150	2700	8050	6100	T&G	Lifting Loops cast in
2700	1000 1250 1500 2000	150	3000	9050	8170	T&G	Lifting Loops cast in
3000	1000 1250 1500 2000	180	3360	10000	11775	T&G	Lifting Loops cast in

*Bespoke Catchpits can be made up to sizes of DN3600mm

**Bespoke Catchpits can be made height of up to 2.5m

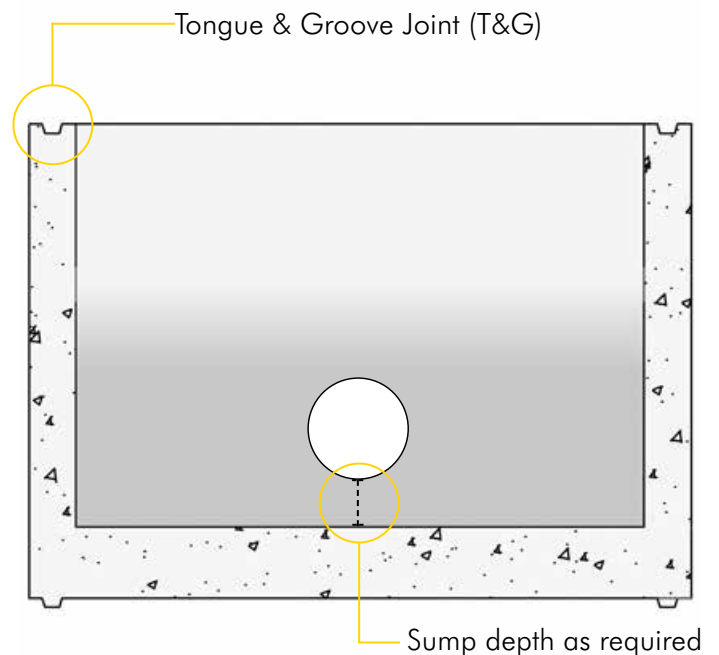

WATERTIGHT CATCHPITS DN 1200 & 1500

A Watertight Catchpit is similar to a standard Catchpit but is manufactured with a wider wall and is sealed with a watertight rubber seal. No concrete surround is required on-site as the chamber can be backfilled after completion saving time and costs on-site.

WATERTIGHT CATCHPITS / DN1200 - 1500

Internal Dia	Depths*	Wall Thickness	Overall Dia	Circum	Approx Weight	Type of Joint	Lifting
mm	mm	mm	mm	mm	KG	-	-
1200	1000 1250 1500 2000	130	1460	4712	1780	Watertight	3 x 2.5T Shackles
1500	1000 1250 1500 2000	150	1800	5655	2825	Watertight	Lifting Loops cast in

*Bespoke Catchpits can be made height of up to 2.5m

ADVANTAGES

- Complete watertight chamber
- Off-site solution
- Simple & fast installation
- Can be fitted with any type of pipe
- Reduced time in confined spaces
- Low carbon footprint

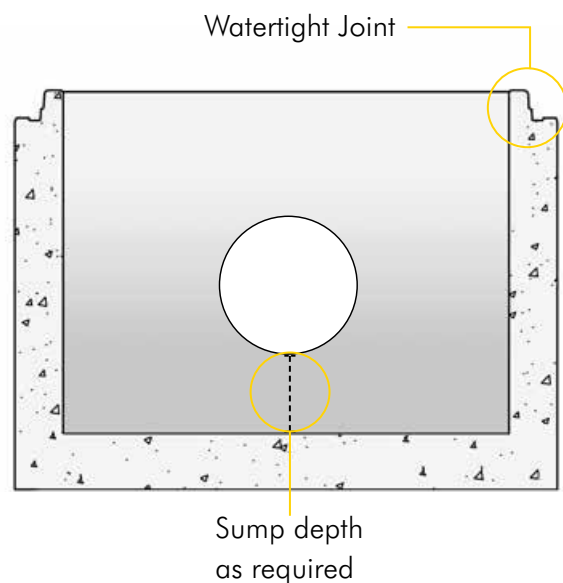

HEADWALLS DN150 - 2100

Designed in accordance with Eurocode 2 & Eurocode 7 we manufacture a wide range of precast concrete Headwalls in various sizes to suit any type of pipe connecting into open water areas including collection ponds and rivers. Concrete headwalls can preserve the surrounding environment by reducing erosion at the outfall connection.

HEADWALLS / DN150 - 2100

Sizes	Openings (mm)	To Suit Pipe Sizes (mm)	Wall Thickness (mm)	Approx Weight (KG)	Lifting Equipment
Small	190 - 640	150 - 450	100 & 150	1500	4No RD24 Lifting Loops
Medium	640 - 990	450 - 750	150	2460	4No RD24 Lifting Loops
Large	640 - 1320	450 - 1050	150	3460	4No RD30 Lifting Loops
X Large (2 Pieces)	1320 - 1900	1050 - 1350	250	Part A: 6000 Part B: 6000	3No 10T Shackles
XX Large (2 Pieces)	1510 - 2500	1200 - 2100	250	Part A: 8000 Part B: 8000	3No 10T Shackles

Weights of headwall may vary depending on opening size
PDF and DWG drawings are available to download from www.traceyconcrete.com

OPTIONS AVAILABLE

- Hand railings, gratings, flap valves and weir walls
- Special toe pieces
- Bespoke Headwalls manufactured on request
- Water proofing on request
- Box culvert headwalls
- Full drawing designs and calculations provided

ADVANTAGES

- Simple & fast installation
- 120 year design life
- No on-site shuttering required
- Complete off-site solution
- No part-load charges for readymix concrete
- Prevents soil erosion



HEADWALLS DN150 - 2100

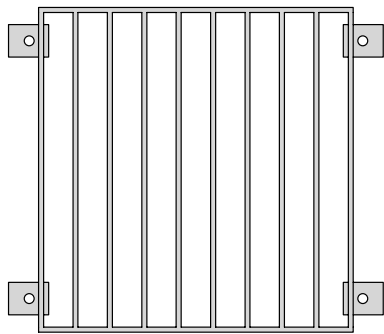

Standard Grate

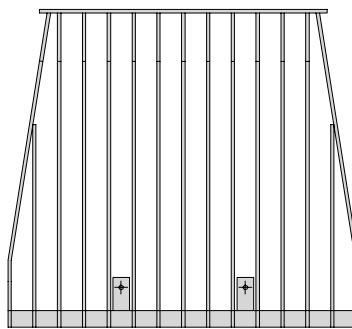

Cranked Grate

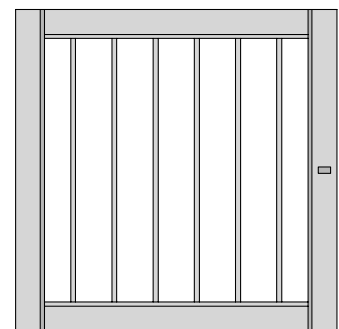

Hinged Grate

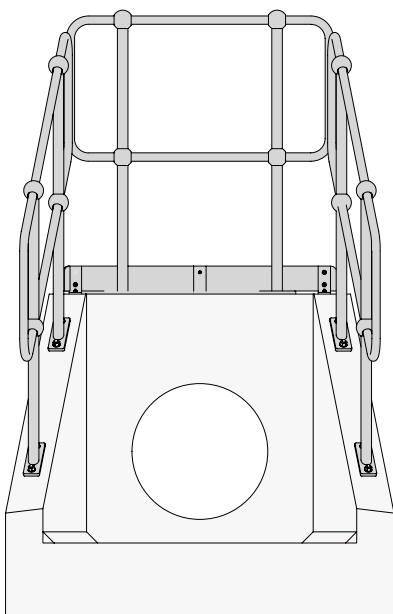

Handrails

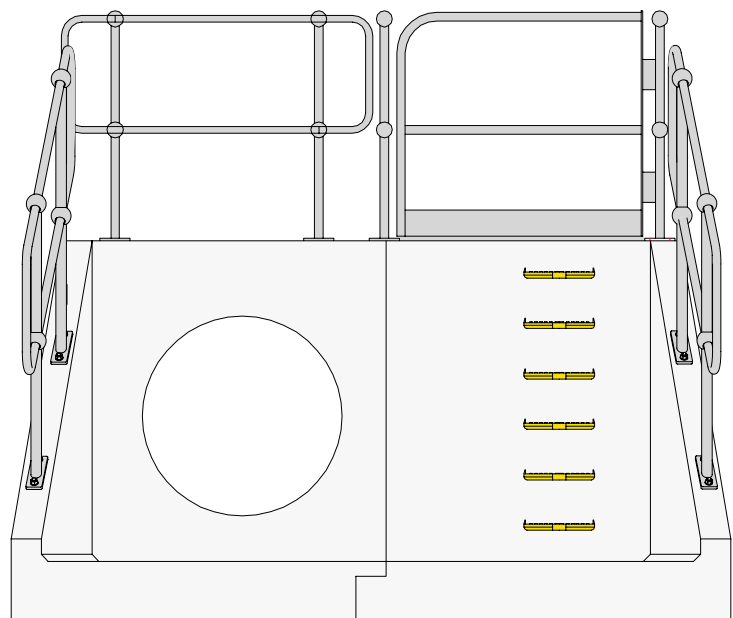

Rungs fitted, handrails & gate on double headwall

Tracey Concrete Sewers for Adoption precast headwalls should be used when part of a Section 104 Agreement and the sewers are to be adopted once completed by the local Water Company. The materials used and installation must comply with the 'Sewers for Adoption' guidelines. Adjustable options to meet SFA:

- Backwall heights
- Single or multiple pipe openings
- Specifiable pipe invert levels

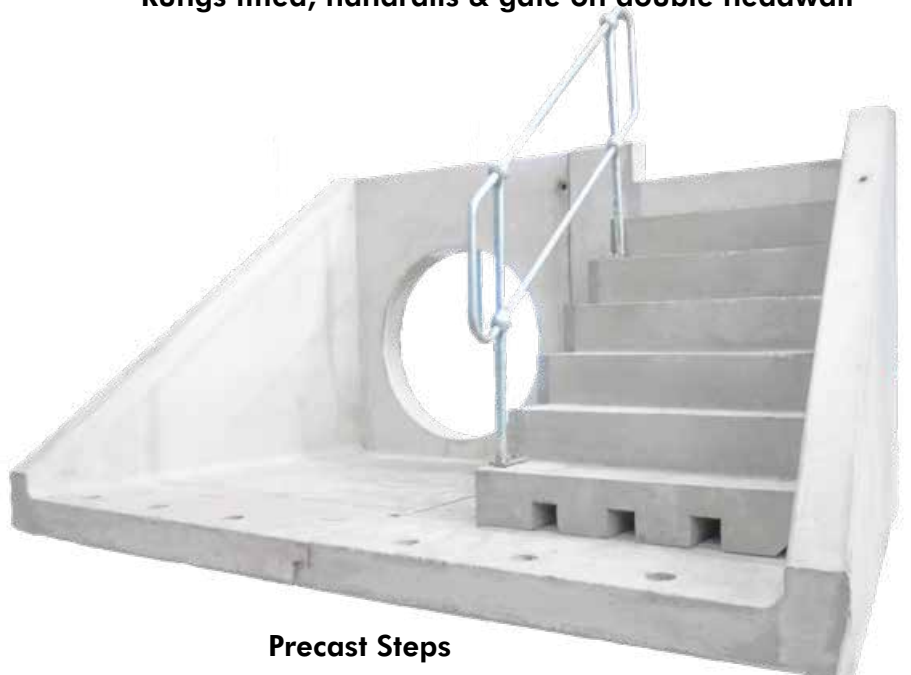

Precast Steps

HEADWALLS

CAST IN LADDERS & STEPS

Tracey Concrete can cast in Ladder steps to headwalls for safe access. The rungs meet the relevant requirements for both steps and ladders and can be used with or without the stringers. The incorporation of the rung in the manhole automatically takes account of variation in depth to design.

Manufactured to BS EN 14396: 2004

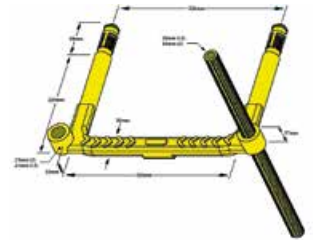

EXTENDED TOE PIECES 250 | 500 | 750 | 1000

Extended headwall toe pieces are designed to secure the headwall in position for challenging ground conditions.

We can design and manufacture any specified design of a toe piece. Standard lengths are 250mm, 500mm, 750mm and 1000mm.

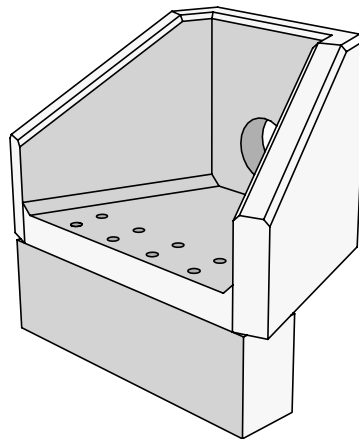

ORIFICE PLATES, PENSTOCKS & FLAP VALVES

Tracey Concrete can supply and fit the full range of Orifice plates, Penstocks & Flap Valves. Contact our sales team for more details

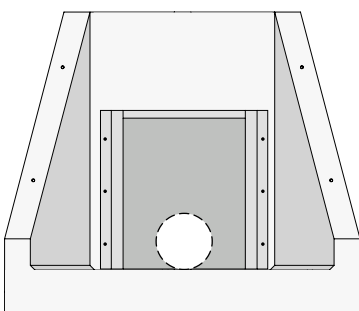

Orifice plate

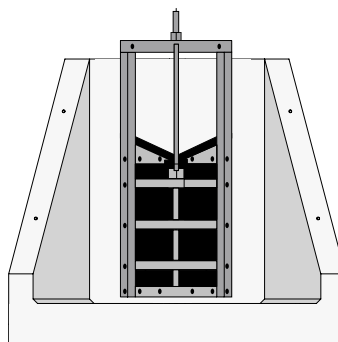

Penstock

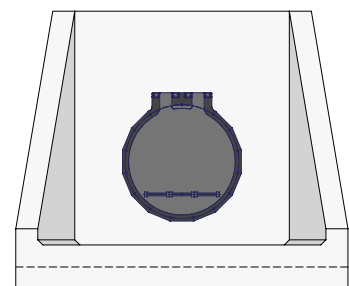

Flap Valve

HEADWALLS

ADJUSTABLE OPENING POSITIONS & SPECIFIABLE PIPE INVERT LEVELS

Tracey Concrete can produce headwalls with adjustable opening positions and specifiable pipe invert levels. If you require a bespoke headwall opening please submit a drawing to our technical team to produce.

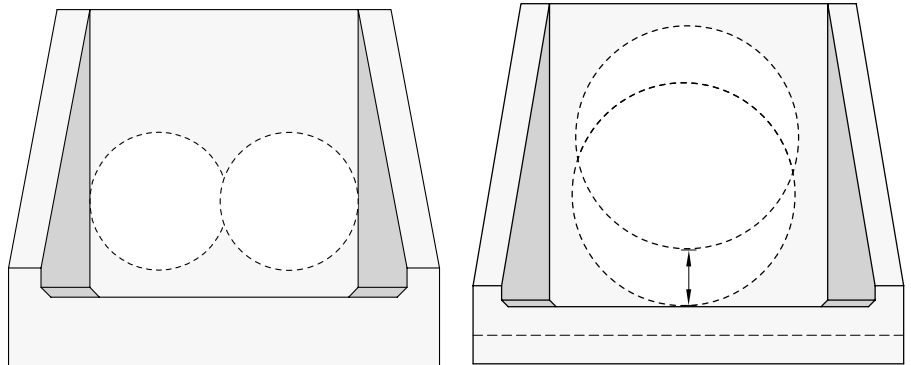

BAFFLE BLOCKS

Tracey Concrete manufacture concrete headwalls with precast baffle blocks on the spillway. We factory fit the baffle blocks to our precast headwalls ensuring they fit properly every time and reducing installation time on site. Baffle blocks slow down the flow of water discharging from the pipe across the spillway of the headwall before entering the watercourse.

BITUMEN COATING

Tracey Concrete can produce headwalls with a bitumen paint coat for added waterproofing. The bitumen extends the life of the headwall waterproofing properties.

The headwall is coated after production under factory conditions and can be installed on arrival to site saving time.



PRODUCT LIFTING EQUIPMENT

All precast concrete products manufactured by Tracey Concrete are designed to be offloaded & installed safely when using the specified equipment - See table below. If you require the correct lifting equipment, please contact our sales department.

Please ensure all lifting equipment is ordered with or on-site ready for when the products are delivered.



This table is subject to change, if you have any questions regarding the lifting of our products please contact us. Please note it is the contractors responsibility to ensure all lifts are safe and compliant with legal requirements.

PRODUCT LIFTING EQUIPMENT

Product	Lifters	Details
		<u>Spigot & Socket Pipe</u> Spherical Lift Shackles DN1200+ - 2No 10T
		<u>Manhole Ring</u> 38mm Lifting Pins DN900 - 2700 3No 38mm DN3000 - 3600 4No 38mm
		<u>Perfect Base™</u> Spherical Lift Shackles DN1200 - 3No 2.5T DN1500 - 3No 5T DN1800/2100- 3No 7.5-10T
		<u>Manhole Cover Slab</u> Cast in Loops See page 25 for Product Weights
		<u>Headwall</u> Small - Medium - 4No RD24 Large - 4No RD30 XL - XXL - 3No 10T Spherical Lift Shackles
		<u>Watertight Manhole Ring</u> Spherical Lift Shackles DN1200 - 3No 2.5T DN1500 - 3No 5T
		<u>Catchpit</u> Cast in Loops See Page 50 & 51 for Product Weights

Certified lifting equipment is available for all our precast products.
Please download our lifting guides at www.traceyconcrete.com or email headoffice@traceyconcrete.com for a copy.

MEET THE IRELAND TEAM



Darren Maguire (MEI) 
Irish Sales Manager
Mob: 07971100854
E: darren@traceyconcrete.com



Agne McCusker
Internal Sales
T: 028 / 048 66326437
E: agne@traceyconcrete.com



Jackie Curry 
Despatch Manager
T: 028 / 048 66326437
E: jackie@traceyconcrete.com



Stephen Maguire 
Technical Engineer
T: 028 / 048 66326437
E: stephen@traceyconcrete.com



Paddy Corrigan 
Technical Engineer
T: 028 / 048 66326437
E: paddy@traceyconcrete.com



Neil Thornton (MEI) 
Technical Engineer
T: 028 / 048 66326437
E: neil@traceyconcrete.com



Anthony McManus
Irish Accounts / Sales
T: 028 / 048 66326437
E: anthony@traceyconcrete.com



Ryan O'Hanlon
Technical Engineer
T: 028 / 048 66326437
E: ryan@traceyconcrete.com



Tahreer M. Fayyad 
Technical Engineer
T: 028 / 048 66326437
E: tahreer@traceyconcrete.com

SPONSORSHIP

Tracey Concrete have been the main sponsor of Fermanagh GAA since 1991 which is the longest in GAA History. We at Tracey Concrete understand the importance of supporting community based organisations. We also sponsor our local Rugby Club at youth level - Enniskillen RFC



CHARITY WORK

Marie Curie is our chosen charity. We take part in the Lady Of The Lake Festival each year to raise funds for Marie Curie. In 2019 we raised £5,250.00



Our UK National Sales Manager John Nabbs at the top of Croagh Patrick in aid of Stand Up to Cancer.

CORONA VIRUS - COVID 19

During the Corona Virus - Covid 19 Pandemic Tracey Concrete donated over 300 No FP3 Masks and PPE to our local hospitals and nursing homes. All our employees who continued to work through this time have access to masks, gloves, visors and at a social distance of over 2m. Our procedures were reviewed and changed to suit the requirements set out by the government.

Coronavirus COVID-19



Coronavirus
COVID-19
Public Health
Advice





Tracey Concrete Limited
Old Rossorry, Sligo Road
Enniskillen, Co. Fermanagh
BT74 7LF

Belcoo Quarry
Greenahoe Road, Belcoo
Co. Fermanagh
BT93 5HD

TELEPHONE
028 6632 6437

EMAIL
headoffice@traceyconcrete.com
traceyconcrete.com

