



## T1G3 - STEEL MANHOLE COVER

### KEY FEATURES

- Integrated lifting handles each tested to 60Kg of direct lift
- Factory fitted rubber sealing gasket to prevent unwanted odours
- Tray fully galvanised to BS EN 1461:2009
- Moulded grouting flange



### T1G3 - Specifications

Product Weight (Kg)	7.5
Clear Opening	220-300 Dia
Overall Dimensions	440 x 440 x 52
Cover Material	Mild Steel to EN 10346 2015 DD11
Frame Material	Polypropylene (Grade AP9)
Load Rating	5 tonne GPW
Load Rating Data	12.5kN held for 30 seconds
FACTA Clauses	7.0, 7.2, 7.2.1, 7.2.3
Application	Pedestrian Areas
Locking	Locking screws and sealing gasket

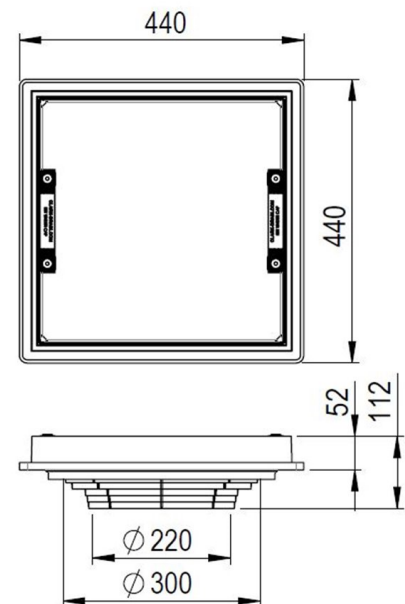

T1G3/V0.1/09-12-2022

Due to our continuous product improvement program features and sizes may be subject to change without notice.

CLARK DRAIN, STATION ROAD, YAXLEY, PETERBOROUGH, PE7 3EQ, TEL. +44 (0) 1733 765317